

HF Radio Family



R&S® Series 2000



R&S® Series 2000 HF Radio Family

Advanced digital shortwave communications

With the R&S® Series 2000 HF radio family, Rohde & Schwarz is continuing its long-standing tradition in the field of shortwave communications. The R&S® Series 2000 line includes transceiver and receiver systems for mobile and stationary use with powers of 150 W, 500 W and 1000 W.

The R&S® Series 2000 not only provides the full range of standard radiocommunications functions; it also offers a wide variety of applications by means of useful options.

- ◆ Shortwave telephone
- ◆ Data transmission up to 9.6 kbit/s
- ◆ LINK expandability
- ◆ SELCAL expandability
- ◆ User-friendly HMI
- ◆ Plug-in options
- ◆ Conformance certification by Defense Information Systems Agency (JITC)
 - MIL-STD-188-141B, App. A+B
 - STANAG 5511
 - STANAG 4203, Annexes B+C

Communications take place in line with international standards. Fast and reliable data transmission as well as message handling allow the R&S® Series 2000 to be integrated into modern multimedia systems, thus providing the basis for reliable, worldwide communications independent of existing infrastructures. It is possible to set up high-power broadband communications systems on the basis of the R&S® Series 2000 components for transmissions on multiple channels with low frequency separation and in different emission modes.

Versatility built into the basic configuration

The R&S® Series 2000 in its basic configuration is capable of transmitting Morse, speech and teletype data. All common classes of emission such as J3E (USB, LSB), B8E, H3E, A1A, F1B, weather fax and F3E are available. The system can thus be used both for high-quality J3E, H3E, F3E radiotelephony and for teletype and data transmissions with a rate up to 600 Bd. With a lower frequency limit of 1.5 MHz, radiocommunications via ground waves are possible, giving particularly reliable communications links. Completely new areas of application are opened up by a variety of **options**, provided mostly as **plug-in modules** for the base unit.

Options for versatile application

Automatic link establishment (ALE)

The R&S® GS2200 data link processor automatically sets up the optimum radiocommunications link using the adaptive Rohde & Schwarz ALIS procedure or MIL-STD-188-141B, App. A+B. As for ALIS, this procedure is 100 % compatible with the R&S® Series 850 family of radio equipment.

High RF selectivity

The optional R&S® FK2020/FK2040 digitally tuned RF selectors with a tuning time of only 10 ms enable fast frequency changes. Selectivity is up to 40 dB at 10 % frequency spacing in the transmission and reception mode, while far-off selectivity exceeds 70 dB. The input is protected against overvoltages up to 200 V EMF.

High-speed data transmission

The transmission rate can be markedly increased (up to 9.6 kbit/s) by means of the internal R&S® GM2200 HF modem. This enables the transmission and reception of telefax messages, computer data, and color video still pictures, for example. Connection between the data terminal and the R&S® Series 2000 is made by a commercial off-the-shelf (COTS) PC with the appropriate software.

Remote control facilities

One or more R&S® Series 2000 transceivers can be remotely controlled – over any distance and for all settings – from either the R&S® GB2000 remote control unit, the R&S® GP2000 RC processor and/or from a PC.

Simultaneous connection of two remote control facilities (as above) is possible. Operating in addressed mode, up to 99 transceivers are controllable using the integrated (bus-capable) serial

RS-485 interface. On the R&S® GB2000 remote control unit, various hardware- or software-configured AF (in/out) and PTT modes can be selected. This facilitates adaptations and integration into existing voice/data/control (PTT) facilities. Full PC control of one or more R&S® Series 2000 transceivers from a PC can easily be implemented either with remote control software or with customer-written programs. The transparent ASCII command format required for the R&S® Series 2000 control will be accepted by any software language.

Shortwave telephone links

The optional R&S® GN2100 automatic phone patch (APP) allows a telephone to be linked to a private automatic branch exchange (PABX). The R&S® GS2200 data link processor establishes the radio link with the called subscriber, who can be dialed directly in half-duplex mode; transmit/receive switchover is voice-controlled by means of a VOX circuit. The R&S® GN2100 automatically adapts itself to telephone lines of varying quality. Instead of connection to the PABX, direct connection can be made to the public switched telephone network (PSTN), provided official regulations make allowance for this. As a matter of course, the R&S® Series 2000 offers all the amenities of a modern telephone set: short-code dialing memory, optional pulse or dual-tone multifrequency dialing (DTMF).



Worldwide communications with high reliability and great ease of operation: R&S® Series 2000 HF radio family.

High quality of speech and privacy

Digital voice option

The R&S®GN2130 is a plug-in vocoder module with integrated crypto processor for the R&S®Series 2000 HF equipment. It can be used together with the R&S®XK2100 150 W transceivers, the R&S®GX2900 exciters, the R&S®EK2000 receivers or the R&S®GP2000 remote control processors. The option considerably enhances the quality of voice links and, above all, provides digital ciphering of voice signals.

The COMSEC part of the R&S®GN2130 is based on the SCR95 crypto algorithm. This strong algorithm uses key lengths of up to 256 bits (approx. 10^{77} variants). Assuming even uninterrupted transmission, the same bit sequence would not be repeated for about 2×10^9 years. The algorithm can be adapted to user requirements (option). With this concept, each user can benefit from a unique user key set. The keys required for ciphering

are stored inside the module but can be distributed by appropriate hardware. A stored key set contains 4096 independent keys that can be selected from the key set menu of the R&S®Series 2000 HMI. The R&S®GN2130 supports plain override. This feature allows reception of analog voice on the currently selected channel with the transceiver set to digital operation. This prevents analog calls from being missed while working in digital voice mode. To answer an analog call, the operator simply has to switch to analog (SSB) mode temporarily.

R&S®GN2110 voice processing unit

Using digital signal processing (DSP), the R&S®GN2110 digital voice processing unit considerably improves speech intelligibility by suppressing noise and interference in the transmission or the reception mode. This option also allows voice control of squelch and VOX circuits.

Three power classes

The system is available in three versions with different output powers:

- ◆ R&S®XK2100 with 150 W
- ◆ R&S®XK2500 with 500 W
- ◆ R&S®XK2900 with 1000 W

Each transceiver system comprises a receiver-exciter, an amplifier, a power supply, an antenna tuning unit, and internal and external options. All units are available as rackmount models.

The R&S®Series 2000 is used for reception in the range 10 kHz to 30 MHz and for transmission in the range 1.5 MHz to 30 MHz. Broadband antennas can be connected directly to the system. Optimum antenna matching is provided for each power class by means of the R&S®FK2100, R&S®FK855 and R&S®FK2900M antenna tuning units.

	R&S®XK2100 150 W	R&S®XK2500 500 W	R&S®XK2900 1000 W
Antennas	e.g. R&S®HX002A1/M1	e.g. R&S®HX002	
ATUs	e.g. R&S®FK2100	e.g. R&S®FK855/FK2900M	
Transceiver systems and accessories (options)	R&S®XK2100 transceiver	R&S®VK2500 power amplifier	R&S®VK2900 power amplifier
	R&S®IN2100 power supply	R&S®GX2900 receiver-exciter	
		R&S®IN4150 power supply	R&S®IN4190 power supply
	Internal options	Internal options	

The R&S®Series 2000 HF radio family is available in three power classes: 150 W, 500 W and 1000 W. The diagram shows the basic system configuration with recommended ATUs and antennas.

Tried and tested technology

The R&S® Series 2000 HF radio family is highly modern both in terms of hardware and software. This includes, for example, digital signal processing (DSP) in the transmitting and receiving sections, and internal instrument control by means of a fast, serial control bus. This allows hardware extensions (options) to be integrated quickly and easily and software updates to be made conveniently via an RS-232-C interface. Plain-text display of faults down to the module level by means of the built-in test system (BIT) greatly facilitates troubleshooting and servicing.

Great importance has been attached to electromagnetic compatibility (EMC). The relevant requirements of MIL-STD-461 are fulfilled.

The core of the R&S® Series 2000 family is formed by the R&S® XK2100 (150 W transceiver) and R&S® GX2900 (receiver-exciter for the 500 W and 1000 W versions) base units. These units include, in their basic configuration, six exchangeable modules and a number of spare slots for options (see block diagram on page 6).

The options are detected by the unit upon plug-in and are immediately operational following a simple software update.

The **central control unit** incorporates a powerful microprocessor that coordinates all internal control sequences for the modules via the SERBUS and communicates with external equipment via two data interfaces (RS-232-C, RS-485) and via the keypad, which can be used for making phone calls, for example. The microprocessor also generates the messages and indications output on the graphic display.

A total of approx. 1000 complete channel settings can be stored in an EEPROM without a buffer battery being required.

The channel memory is allocated as follows:

- ◆ 401 user-programmable channels, including 100 frequency pairs for half-duplex operation
- ◆ Fixed programmed ITU channels with allocated numbers between 401 and 2240
- ◆ 120 half-duplex channels for operation using automatic link establishment (ALE)

The use of digital signal processing in the **IF/AF processor** affords a number of special features:

- ◆ **Variety of classes of emission** such as
 - H3E, A1A, J3E (USB, LSB), F3E
 - B8E (ISB)
 - F1B (FSK, AFSK)
 - J2D (with external modem)
- ◆ **17 bandwidths** from 50 Hz to 8 kHz with group-delay-equalized filters for data transmission
- ◆ **Five decay time constants** between 25 ms and 3 s
- ◆ **Passband tuning** (with bargraph indication)
- ◆ **Notch filter** (with bargraph indication)
- ◆ **Noise blanker** (interference suppression)
- ◆ **Syllabic squelch** (no threshold setting)
- ◆ **Voice compression** (increase of output power for voice transmission)

Excellent large-signal characteristics are obtained by means of a high-power mixer stage in the **RF/synthesizer section**. Intercept points are typically at +70 dBm (IP2) and +35 dBm (IP3); cross-modulation is 10% with an interference source of +20 dBm.



R&S® GX2900 receiver-exciter.

The sensitivity of the receiving section is considerably increased by means of a switchable preamplifier, yielding a noise figure of 9 dB. This ensures good reception also with short rod or whip antennas. The unit will withstand overvoltages up to 100 V EMF for an indefinite period of time owing to an input voltage protection circuit.

The **amplifier** incorporated in the R&S®XK2100 outputs a transmit signal of 150 W (PEP) or 100 W in the CW mode. For CW and data operation, it is mandatory to use a blower unit (option). In the R&S®GX2900 for the 500 W and 1000 W systems, the 150 W amplifier is replaced by an amplifier interface for connecting the R&S®VK2500/VK2900 power amplifiers.

The power will automatically be cut back in the event of mismatch or thermal overload in all three power classes of the transceiver. If one of the 500 W output stages fails in systems with the R&S®VK2900 power amplifier, transmission can be continued with an output power of 500 W.

The R&S®ZW2900 option can be integrated into the R&S®VK2500/VK2900 to provide additional overvoltage protection for the receiver input. In conjunction with the optional R&S®FK2020/FK2040 digitally tuned RF selectors, the R&S®ZW2900 enables operation with voltages up to 100 V (V_{rms}).

All interface lines pass through an integrated **EMC filter**. Radiated and conducted interference is effectively suppressed by filters and protective diodes.

User-friendly operation

The R&S®Series 2000 HF radio family is outstanding for its high user-friendliness, featuring menu guidance on a high-contrast, large-size LC graphic display and providing a number of convenient controls and displays such as:

- ◆ Softkeys
- ◆ Cursor keys
- ◆ Step keys (rollkey editor)
- ◆ Message, selection and editing windows
- ◆ Numeric editor
- ◆ Icons for menu and system status indication

In addition to plain-text messages, bargraphs are used to indicate the receive field strength, output power, etc. The control functions are logically combined in the menus and can thus be found easily.

The clear-cut display makes operation of the R&S®Series 2000 easy even for the non-specialist. Users with expertise can go to a more complex menu level upon entering a password and configure the equipment as required to suit a wide variety of applications.

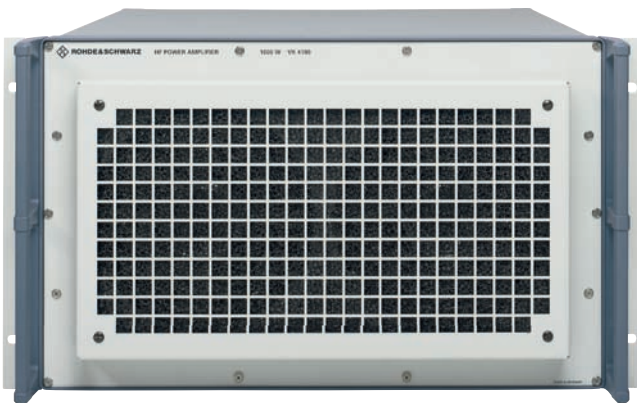

R&S®VK2900 1000 W HF power amplifier.

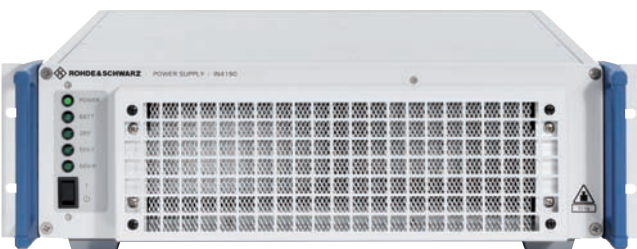

R&S®IN4190 power supply.

Suitable for use in harsh environments

The R&S® Series 2000 HF radio family was designed for operation under adverse environmental conditions and can be used not only in fixed stations but also on vehicles and ships. Shock absorbers are available for the R&S® XK2100 to protect the units in applications involving high levels of shock and vibration. Proper operation of the system will not be impaired by varying climatic conditions, problematic EMC environments or supply voltage fluctuations.

Selective level control

The usual transmitter power control using broadband directional couplers as sensors can often not be employed, since backdoor power components from neighboring transceivers activate the transmitter power control and thus reduce the transmitter power, although there is no actual mismatch in the line under observation. Problems of this kind are likely to occur in applications where antennas are closely co-sited (e.g. co-location on board ships), or where frequency spacing is very small.

The HF transceivers with selective level control feature narrowband evaluation of the forward and reflected power at the wanted frequency so that the transmitter power control is not affected by RF power coupled in from other transmitters in the system.

Optimum matching

Optimum matching of the antennas is achieved by means of the R&S® FK2900M for the 500 W and the 1000 W systems, and by means of the R&S® FK2100/FK2100M for the 150 W system.

All ATUs are fully arc-protected against direct lightning strokes. They are tested to withstand arcs of 10 kV/10 kA. An automatic BIT (built-in test) provides fault detection and reporting to the R&S® Series 2000 transceiver/exciter respectively.

The antenna tuning unit provides automatic matching of antennas. Two ATU versions are available:

- ◆ Landmobile version
- ◆ Naval version (for shipboard use)

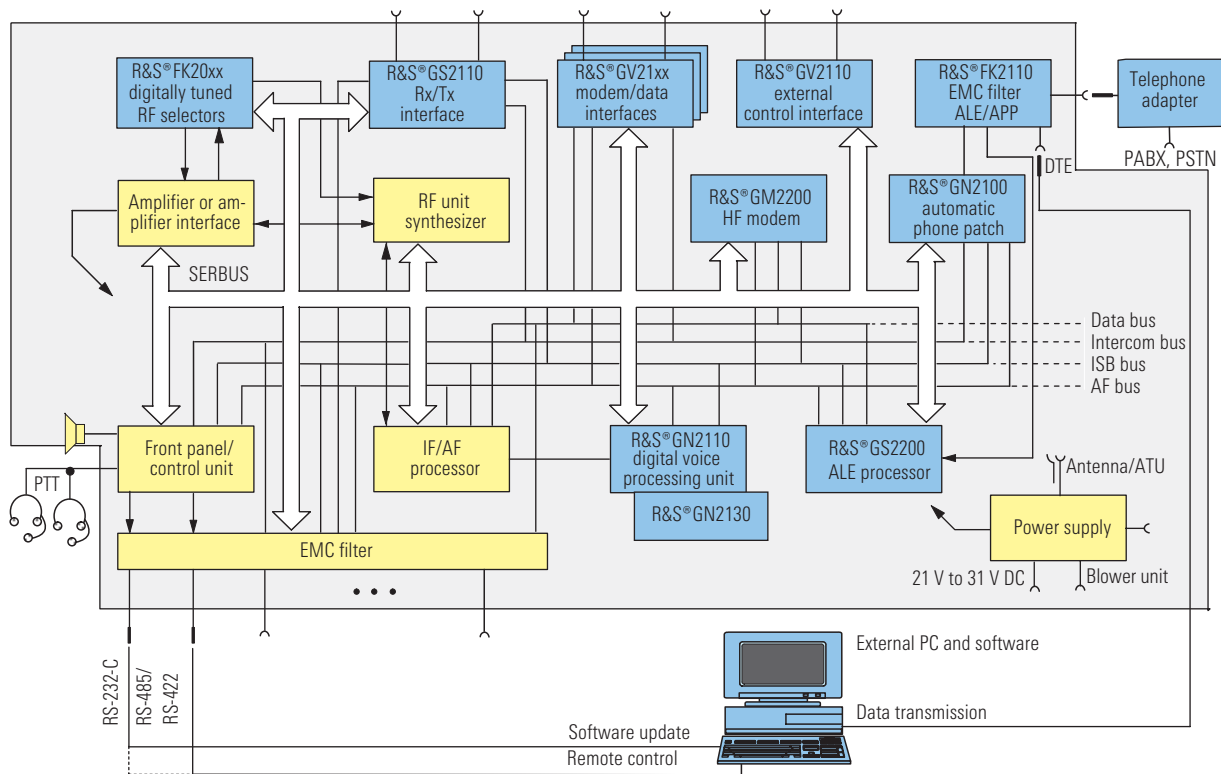

Block diagram of the R&S® XK2100 and R&S® GX2900: the base units of the R&S® Series 2000 systems are equipped with six standard modules and provide spare slots for options (blue). Software updates are conveniently performed from a PC via the RS-232-C interface.

The R&S®FK2100M, which is a sea-water- and drop-resistant version, is especially designed for shipboard applications and can match antennas with very low ohmic resistance.

Microprocessor-controlled tuning allows self-learning of a maximum of 1500 settings that, together with the channels stored in the R&S®XK2100 transceiver (including ALE, APP, ITU and 100 silent channels), are retained in non-volatile memory. The stored channels can be called up with very short setting times.

Failsafe power supply

The external power supplies are intended for stationary applications. They are in the form of a primary switched-mode power supply for all three power classes of the transceiver and comply with the relevant safety and EMC regulations.

The R&S®IN4150 and R&S®IN4190 were designed for single- or three-phase operation. For special AC supply

voltages, e.g. in maritime applications, the R&S®BV2900 transformer is available as an option, which can be incorporated in the transceiver rack.

When an emergency power supply (e.g. a 24 V battery) is used, AC supply/battery switchover will be effected instantaneously in the event of a power failure, thus ensuring uninterrupted radiocommunications.¹⁾



R&S®FK2100 antenna tuning unit.

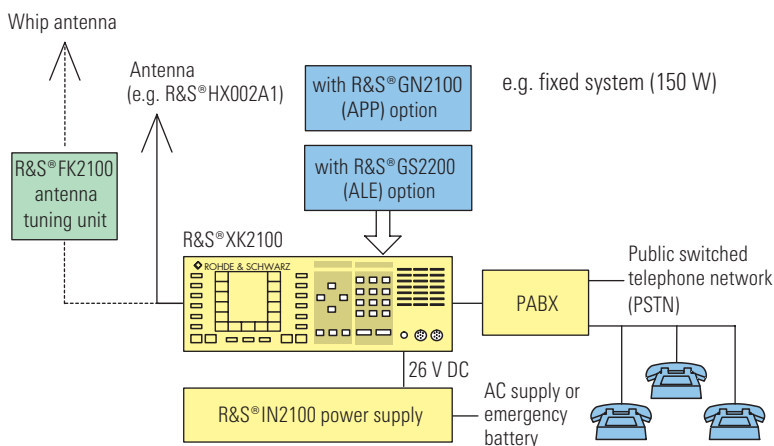

Transceivers of the R&S®Series 2000 family (in this example R&S®XK2100) can be connected to a private automatic branch exchange (PABX), allowing telephone communications via shortwave independent of the available infrastructure.

¹⁾ At reduced power with 500 W and 1000 W systems.

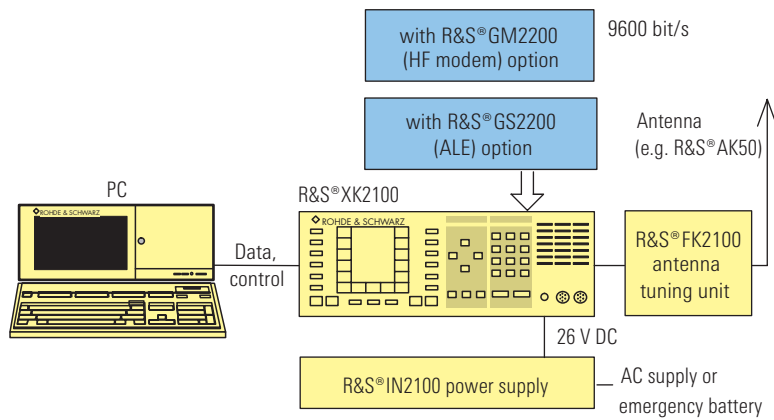

With the optional HF modem incorporated in the transceiver, transmission rates of up to 9600 bit/s can be achieved. This allows the transmission and reception of data files, for example.

System expansion options

The base R&S®XK2100 transceivers as well as the R&S®GX2900 receiver-exciter are already fully prepared to accommodate optional interfaces that are available as plug-in units and are located at the rear of the equipment. Various interface options are available for easy matching and proper connection of external (e.g. customer-provided) HF modems, link processors, data terminal sets, or system processors, encryption devices, etc., as well as for the control and operation of system-specific options such as RF filters, power selectors, duplex receivers, naval distress and alarm facilities (DSC/GMDSS), and remote control units.

For HF telephone operation along with the integrated ALE and APP options, direct connection of a PABX or a PSTN line is possible using the ALE/APP interface option. Up to four interface options can be accommodated at a time.

High-speed data mode

Depending on the system configuration, either with integrated or external ALE and/or HF modem, various interface options such as the R&S®FK2110 EMC filter or the R&S®GV2130 modem data interface are available for connection to external HF modems, data sources, data-protection or link processors.

Data link expandability

The R&S®GV2120 data link interface is provided for connecting an external data terminal set (DTS) that complies with MIL-STD-188-203-1A and STANAG 5511.

Full-duplex or split-site operation

The R&S®GS2110 Rx/Tx interface is available for full-duplex operation (controlling an external receiver or transmitter).

For operations at different sites, a R&S®GP2000 split site controller is available to control separate transmitter and receiver sites from one center, also allowing ALE, fast data, and HF telephone modes.

Specifications

Transmission

	R&S®XK2100	R&S®XK2500	R&S®XK2900
Frequency range	1.5 MHz to 30 MHz	1.5 MHz to 30 MHz	1.5 MHz to 30 MHz
Output power into 50 Ω, VSWR ≤1.5	150 W ±1 dB PEP, 100 W ±1 dB CW	500 W ±1 dB PEP or CW (400 W ±1 dB with R&S®FK855 ATU)	1000 W ±1 dB PEP or CW
Power levels	10/30/100 W	40/100/500 W	100/500/1000 W
Spurious suppression ¹⁾	>70 dBc	>70 dBc	>70 dBc
Harmonics suppression	typ. 60 dBc	typ. 60 dBc	typ. 60 dBc
Intermodulation products (referenced to PEP)	>32 dB	>36 dB	>36 dB
S/N ratio ²⁾	>150 dBc (1 Hz)	>150 dBc (1 Hz)	>150 dBc (1 Hz)
Carrier suppression	typ. 70 dB	typ. 70 dB	typ. 70 dB
Suppression of unwanted sidebands	>60 dB	>60 dB	>60 dB
Voice compression (VC)	built-in, power increase with radiotelephony		

Frequency setting	decadic in 1 Hz steps
Channel memory	
User-programmable channels	401
Including half-duplex channels	100 (transmit and receive frequencies separately programmable)
Fixed programmed channels (ITU)	channel numbers between 401 and 2240 (half-duplex)
Additional channels for ALE	120 (half-duplex)
Frequency error	
Standard (TCXO)	<2 × 10 ⁻⁹ /°C
Optional (OCXO)	<1 × 10 ⁻⁹ /°C, <1 × 10 ⁻⁹ /day
Aging	
Standard (TCXO)	<1 × 10 ⁻⁶ /year
Optional (OCXO)	<1 × 10 ⁻⁷ /year
Classes of emission	A1A (CW), J3E (SSB, USB/LSB), H3E (AME), B8E (ISB), F1B (FSK, AFSK, 50 Bd to 600 Bd, shift 42.5 Hz to 425 Hz), F3E (FM), F3C, A3E (AM) (reception only), J2D (with external modem), MIL-STD-188-203-1A (optional)

Reception

Frequency range	10 kHz to 30 MHz
Input impedance	50 Ω, VSWR <3
Input sensitivity (for S/N = 10 dB, f = 0.2 MHz to 30 MHz)	
Without preamplifier and preselection A1A (CW) J3E (SSB) H3E (AME), 1 kHz, m = 60%	typ. 0.4 μV EMF, BW = 300 Hz ³⁾ typ. 1.0 μV EMF, BW = 2.7 kHz ⁴⁾ typ. 2.7 μV EMF, BW = 6 kHz ⁴⁾

With preamplifier, without preselection A1A (CW) J3E (SSB) H3E (AME), 1 kHz, m = 60%	typ. 0.15 μV EMF, BW = 300 Hz ³⁾ typ. 0.4 μV EMF, BW = 2.7 kHz ⁴⁾ typ. 1.0 μV EMF, BW = 6 kHz ⁴⁾
Receiving bandwidths	
3 dB	±25 Hz, ±75 Hz, ±150 Hz, ±200 Hz, ±300 Hz, ±400 Hz, ±500 Hz, ±750 Hz, ±900 Hz, ±1050 Hz, ±1200 Hz, ±1350 Hz, ±1550 Hz, ±1850 Hz, ±2250 Hz, ±3000 Hz, ±4000 Hz
60 dB	±125 Hz, ±150 Hz, ±215 Hz, ±335 Hz, ±430 Hz, ±650 Hz, ±770 Hz, ±1000 Hz, ±1440 Hz, ±1600 Hz, ±1760 Hz, ±1900 Hz, ±2100 Hz, ±2850 Hz, ±3220 Hz, ±4100 Hz, ±5100 Hz
AGC	<3 dB (1 μV to 1 V EMF)
Response to a 60 dB step variation	
Attack time	<10 ms
Decay time	25/150/500 ms, 1 s/3 s (selectable)
AF distortion	
Line output, 0 dBm	<1%
Headphones, loudspeaker	<3% at rated power
Weighted S/N ratio (H3E)	>46 dB SINAD for 1 mV EMF, weighted with filter in line with CCITT (0.41/P53)
Nonlinearities (1.5 MHz to 30 MHz, without preamplifier)	
Blocking	3 dB signal attenuation (Δf = 30 kHz, useful signal 2 mV EMF, interfering signal 5 V EMF)
Desensitization	>20 dB SINAD (Δf > 30 kHz, BW = 2.7 Hz, useful signal 30 μV, interfering signal 100 mV)
Intercept point IP3	typ. 35 dBm (Δf > 30 kHz, interfering signals 2 × 0 dBm)
Crossmodulation	<10% (Δf > 30 kHz, useful signal 1 mV EMF, interfering signal 4 V EMF, 1 kHz, m = 30%)
Noise figure	
Without preamplifier	17 dB
With preamplifier	9 dB
Inherent spurious signals	in line with MIL-STD-188-141B
Immunity to interference	
Image-frequency rejection	typ. 90 dB
IF rejection	typ. 90 dB
Oscillator reradiation	<10 μV (at antenna input)
Protection of receiver input	up to 100 V EMF (f < 30 MHz)
With digitally tuned RF selectors	up to 200 V EMF (f < 30 MHz)

¹⁾ Measured at <0.95 f_c and >1.05 f_c (f_c = center frequency of bandwidth).

²⁾ Measured at f ± 10%, at maximum rated output power, A1A (CW).

³⁾ At 10 dB S/N.

⁴⁾ At 10 dB SINAD.

Options

R&S®FK2020 digitally tuned RF selectors	attenuation >20 dB at >10% from operating frequency
R&S®FK2040 digitally tuned RF selectors	attenuation >40 dB at >10% from operating frequency
R&S®GS2200 data link processor	automatic link establishment (ALE) in line with ALIS or MIL-STD-188-141B, App. A + B, for speech and data transmission
R&S®GN2100 automatic phone patch	call transfer to private automatic branch exchange (PABX) with automatic line matching
R&S®GM2200 HF modem	advanced multimode HF modem with selectable waveforms up to 9.6 kbit/s in line with STANAG 4285, STANAG 4529, STANAG 4539, Annex B, Section 4, R&S®GM2200S (proprietary)
R&S®GN2110 digital voice processing unit	noise and interference suppression, speech squelch, VOX with digital signal processing
R&S®GN2130 digital voice option	2.4 kbit/s VLP vocoder OFDM multicarrier HF modem plus encryption module (R&S®GN2130)
R&S®KL2100 blower unit (R&S®XK2100)	required for cont. data transmission
R&S®GB2000 remote control unit	with modems for distances >50 m; class of protection IP 42 in line with DIN 40050 (IP 54 as an option)
R&S®GP2000 remote control processor	for establishing split-site configurations
R&S®FK2110 EMC filter ALE/APP	APP interface to PABX interface, ALE-DTE interface
R&S®GS2110 Rx/Tx interface	NMEA-183 interface 1) for naval GMDSS systems (an external DSC controller drives an HF transceiver of the R&S® Series 2000 family) 2) control of a detached receiver of the R&S® Series 2000 family

Antenna tuning units (ATUs) and antennas

	R&S®XK2100	R&S®XK2500	R&S®XK2900
Frequency range	1.5 MHz to 30 MHz		
Recommended ATUs	R&S®FK2100 R&S®FK2100M	R&S®FK2900M R&S®FK855C1/C3	R&S®FK2900M R&S®FK859
NVIS antennas	R&S®HX002A1/M1 R&S®HX002		

General data

	R&S®XK2100	R&S®XK2500	R&S®XK2900
Temperature range	MIL-STD-810E, methods 501.3 and 502.3		
Operation	-25 °C to +55 °C	-25 °C to +55 °C	
Storage	-40 °C to +85 °C		
Humidity	MIL-STD-810E, method 507.3		
Mechanical data			
Vibration			
Sinusoidal	(EN 60068-2-6) ⁵⁾	EN 60068-2-6	
Random	MIL-STD-T-28800 (0.01 g ² /Hz, 10 Hz to 300 Hz, 1.9 g rms)		
Shock	(MIL-STD-810E, method 516.4, proc. I) ⁵⁾		
EMC	MIL-STD-461E CE102, CS101, CS114, RS101, RS103, (CE103, CS102, CS106, RE102) ⁶⁾	MIL-STD-461E CE102, CS101, CS114, RE102, RS101, RS103	
MTBF	>9600 h	>5500 h	>5000 h
Class of protection	IP 43/32 ⁶⁾	IP 43/20 ⁶⁾	IP 43/20 ⁶⁾
CE conformity mark	in line with EN 60945, ETSI EN 300373-1/-2/-3 (with restrictions) ⁷⁾		
Dimensions W × H × D in mm (without options)	R&S®XK2100: 443 × 127 × 386 (R&S®IN2100: 440 × 82 × 350)	R&S®GX2900: 481 × 132 × 340 R&S®VK2500: 481 × 281 × 570 R&S®IN4150: 481 × 132 × 570	R&S®GX2900: 481 × 132 × 340 R&S®VK2900: 481 × 281 × 570 R&S®IN4190: 481 × 192 × 570
Weight (without options)	R&S®XK: 15 kg (R&S®IN: 9 kg)	R&S®GX: 13 kg R&S®VK: 34 kg R&S®IN: 24 kg	R&S®GX: 13 kg R&S®VK: 42 kg R&S®IN: 24 kg

Power supplies

	R&S®IN2100	R&S®IN4150	R&S®IN4190
AC supply	230 V (1 phase + N)	230 V (1 phase + N) 208 V (Δ, 3 phases) 230 V (Y, 3 phases + N)	230 V (1 phase + N) 208 V (Δ, 3 phases) 230 V (Y, 3 phases + N)
Input voltage tolerance	88 V to 264 V	+10%, -15%, 47 Hz to 63 Hz	+10%, -15%, 47 Hz to 63 Hz
Input power consumption			
1 phase	max. 0.8 kVA	max. 2.5 kVA	max. 4.5 kVA
3 phases (Y)	–	max. 3.6 kVA	max. 6.5 kVA
3 phases (Δ)	–	max. 3.0 kVA	max. 5.0 kVA
Battery	24 V DC emergency supply		

⁵⁾ Tests in brackets were not verified in conjunction with the R&S®IN2100.

⁶⁾ Front-panel exciter/rest of transceiver.

⁷⁾ R&S®XK2100: ETSI EN 300373-1, 7.6, 9.3, 10.7 (see user manual);
R&S®XK2500/XK2900: ETSI EN 300373-1, 7.6, 8.3, 9.3, 10.1.1, 10.7 (see user manual);
EN 61000-3-2 (see user manual).

General data of power supplies

	R&S®IN2100	R&S®IN4150	R&S®IN4190
Temperature ranges	MIL-STD-810E, method 501.3/502.3	MIL-STD-810F, method 501.4/502.4, EN 60068-2-1/2	
Operating temperature range	0 °C to +50 °C	-25 °C to +55 °C	
Storage temperature range	-40 °C to +85 °C	-40 °C to +70 °C	
Humidity	MIL-STD-810E, method 507.3	MIL-STD-810F, method 507.4	
Vibration (sinusoidal)	–	MIL-STD-167-1, type 1	
Vibration (random)	MIL-STD-T28800	MIL-STD-810F, method 514.5	
Shock resistance	MIL-STD-810E, method 516.4, proc. I	MIL-STD-810F, method 516.5, proc. I, EN 60068-2-27	
EMI/EMC	MIL-STD-461E : CE102, CS101, CS114, RS101, RS103	MIL-STD-461E: CE102, CS101, CS114, RE101, RE102, RS101, RS103	

Ordering information

Designation	Type	Order No.
HF Transceiver 150 W⁸⁾		
Desktop model	R&S®XK2100L	6033.0508.02
Rackmount 19" Adapter R&S®XK2100 R&S®IN2100	R&S®KA2900	6072.6010.03
	R&S®KA2120	6064.0751.02
Naval Software Option	R&S®XK2101S	6090.2758.07
HF Transceiver 500 W⁹⁾		
Model for installation in 19" racks ⁹⁾	R&S®XK2500L	6071.0518.72
Model for installation in 19" racks ⁹⁾ , selective level control	R&S®XK2500L	6071.0518.73
Naval Software Option	R&S®GX2901S	6090.2506.07
HF Transceiver 1000 W⁹⁾		
Model for installation in 19" racks ⁹⁾	R&S®XK2900L	6057.9992.72
Model for installation in 19" racks, selective level control ⁹⁾	R&S®XK2900L	6057.9992.73
Naval Software Option	R&S®GX2901S	6090.2506.07

⁸⁾ HF transceivers equipped with front panel for local and remote control.

⁹⁾ Mating connector sets and cables have to be ordered separately.

¹⁰⁾ Requires R&S®GF2010 high-precision frequency standard.

¹¹⁾ Requires naval software option.

Internal options

Designation	Type	Order No.
Data Link Processor		
	R&S®GS2200	6091.5009.02
Software for R&S®GS2200		
MIL-STD-188-141B, App. A (ALE)	R&S®GS2200S	6091.5709.02
MIL-STD-188-141B, App. A + B, linking protection (ALE)	R&S®GS2201S	6091.5809.02
ALIS (Rohde & Schwarz standard)	R&S®GS2210S	6091.5909.02
Data Link Interface¹⁰⁾		
LINK Y + LINK 11 (CLEW SLEW)	R&S®GV2120	6079.1013.02
LINK Y (CLEW SLEW)	R&S®GV2120	6079.1013.03
HF Modem, multistandard¹⁰⁾	R&S®GM2200	6117.5500.02
Modem Software		
Rohde & Schwarz 2.7 + 5.4 kbit/s	R&S®GM2200S	6117.6006.02
MIL-STD-188-110A Section 5.3 (Single Tone)	R&S®GM2201S	6117.6258.02
STANAG 4285	R&S®GM2202S	6117.6506.02
STANAG 4529	R&S®GM2203S	6117.6758.02
MIL-STD-188-110B App. C or STANAG 4539 Annex B, Section 4	R&S®GM2204S	6117.7002.02
Further options		
High-Precision Frequency Standard (OCXO) (factory-installed only)	R&S®GF2010	6033.5000.02
Blower unit (for R&S®XK2100L)	R&S®KL2100	6050.2992.02
Automatic Phone Patch with Telephone Adapter	R&S®GN2100	6033.9505.02
Digital Voice Processing Unit (NRU)	R&S®GN2110	6033.7502.02
Digital Voice Option (with powerful 256 bit crypto module)	R&S®GN2130	6117.4549.02
Digitally Tuned RF Selectors	R&S®FK2020	6096.9502.02
Digitally Tuned RF Selectors	R&S®FK2040	6096.9902.02
Rx/Tx Interface	R&S®GS2110	6033.5500.02
Receiver Input Protection	R&S®ZW2900	6072.2514.02

External options

Designation	Type	Order No.
Remote Control Unit	R&S®GB2000	6064.2002.02
Remote Control Processor	R&S®GP2000	6092.3000.02
System Receiver	R&S®EK2000	6093.6002.02
440 V Transformer	R&S®BV2900	6072.7016.02
Power Supply (R&S®XK2100)	R&S®IN2100	6050.1996.02
Power Supply 230 V AC; 1 or 3 phases + N / 208 V AC; 3-phase Δ	R&S®IN4150	6120.0705.02
Power Supply 220 V DC	R&S®IN4150	6120.0705.12
Power Supply 230 V AC; 1 or 3 phases + N / 208 V AC; 3-phase Δ	R&S®IN4190	6120.2708.02
Antenna Tuning Unit, 150 W	R&S®FK2100	6046.8948.02
Antenna Tuning Unit, 150 W, naval applications ¹¹⁾	R&S®FK2100M	6046.9550.02
Antenna Tuning Unit, 500 W, naval applications ¹¹⁾	R&S®FK855C3	0724.8908.07
Antenna Tuning Unit, 1 kW, naval applications ¹¹⁾	R&S®FK2900M	6097.1005.02

Recommended extras

Designation	Type	Order No.
Shock Absorber		
For R&S®XK2100	R&S®KS2100	6050.3999.02
For R&S®XK2500/XK2900	R&S®KS2900	6072.6510.02
Service Kit	R&S®KA2110	6050.4995.02
Mating Connector Sets (R&S®Series 2000)		
For R&S®XK2100L	R&S®GK2100	6064.1506.02
For R&S®GB2000	R&S®KA2000B	6070.1633.00
For R&S®GX2900L	R&S®KA2900G	6070.1591.00
For R&S®VK2500/VK2900	R&S®KA2900V	6070.1604.00
For R&S®IN4150/IN4190	R&S®ZF4107	6120.2808.02
Further options and accessories on request		

More information at
www.rohde-schwarz.com



ROHDE & SCHWARZ

www.rohde-schwarz.com

Europe, Africa, Middle East +49 1805 12 42 42* or +49 89 4129 137 74 customersupport@rohde-schwarz.com

North America 1-888-TEST-RSA (1-888-837-8772) customer.support@rsa.rohde-schwarz.com

Latin America +1-410-910-7988 customersupport.la@rohde-schwarz.com

Asia/Pacific +65 65 13 04 88 customersupport.asia@rohde-schwarz.com