

R&S® DVSG Digital Video Signal Generator

Development and quality assurance of TV displays



75 Years of
Driving
Innovation



R&S®DVSG Digital Video Signal Generator At a glance

The R&S®DVSG digital video signal generator supports the development and quality assurance of latest-generation TV sets and projectors. It is a cost-efficient, one-box solution that generates the audio and video signals required for these tasks.

The R&S®DVSG-K10 AV signal generator option makes it possible to test displays with up to 12-bit color depth. The AV signal generator outputs uncompressed video content with a maximum resolution of 1080p and PC resolutions of up to 1920 × 1200 (WUXGA). In addition, Multi-Motion test sequences help enhance picture quality by checking motion blur, deinterlacing and film detection, for example. Comprehensive audio functionalities have been added to the AV signal generator to allow the assessment of sound quality.

The R&S®DVSG-B30 AV signal player option provides exactly the type of signals that a display must be able to handle when operated by an end user. The AV signals are generated on the basis of MPEG-2 transport streams. In addition to the large set of signals supplied with the option, users can also use their own recordings of live signals. This feature makes it possible to easily simulate any live scenario in the lab.

The R&S®DVSG-K20 TS player and recorder option can record and play MPEG-2 transport streams. The numerous transport streams supplied with the option are played in a seamless loop. It is also possible to play transport stream recordings of other devices with no problem.

Key facts

- Digital and analog video and audio output
- HDTV and SDTV formats up to 1080p, PC formats up to WUXGA
- Reference source for moving sequences
- User-selectable variation of interface parameters and signal amplitude
- MPEG-2 transport stream recording and playback



R&S®DVSG

Digital Video Signal Generator

Benefits and key features

Uncompressed, high-precision video and audio signals

R&S®DVSG-K10 AV signal generator option

- ▮ Moving sequences with resolutions up to 1080p (TV) and WUXGA (PC)
- ▮ Deep color (30/36 bit), xvYCC support
- ▮ User-selectable variation of interface parameters and signal amplitude
- ▮ Multichannel audio generation
- ▮ Comprehensive test signal libraries available

▷ [page 4](#)

Output of compressed live signals

R&S®DVSG-B30 AV signal player option

- ▮ Playing of signals with special characteristics: blocking, motion, scene blending
- ▮ Test signal libraries delivered with the AV signal player option

▷ [page 6](#)

Recording and playing of transport streams

R&S®DVSG-K20 TS player and recorder option

- ▮ Seamless playback of transport streams on SPI, ASI and SMPTE310M interfaces
- ▮ Comprehensive transport stream libraries for all relevant broadcast standards: DVB, ATSC, ISDB-T/TB, MediaFLO™, CMMB, ATSC-M/H
- ▮ External R&S®DV-ASC advanced stream combiner software for customer-specific test signals

▷ [page 7](#)

Standard-compliant output via all common video and audio interfaces

- ▮ Digital video/audio interfaces: HDMI 1.3, DVI, SDI, HD-SDI
- ▮ Analog video/audio interfaces: RGB, YPbPr, VGA, S-Video, CCVS, SCART, D4
- ▮ Audio interfaces: S/P-DIF, RCA

▷ [page 8](#)

Fast and easy testing

- ▮ AV signals simultaneously available at the analog and digital interfaces
- ▮ Intuitive and efficient operation
- ▮ Ideal test signal generator for automated and remote-controlled test sequences

▷ [page 9](#)

Uncompressed, high-precision video and audio signals

R&S®DVSG-K10 AV signal generator option

Comprehensive tests are required to assess the functioning of the picture processing unit of a TV set or flat panel display: All the modes that affect resolution, timing and color depth must be verified. To make sure that the quality of the display unit under test is assessed, the test signal source must satisfy extremely high quality requirements. The R&S®DVSG-K10 AV signal generator option fulfills these demanding requirements because it is a purely digital implementation. All picture information bits of a specific test signal are loaded from the RAM directly into the digital processing unit, where they are processed and routed to the AV outputs.

Moving sequences with resolutions up to 1080p (TV) and WUXGA (PC)

The basic signal library contains test sequences with all relevant TV resolutions up to 1080p and VESA-compatible resolutions up to WUXGA. In addition to static artificial test patterns that are used for testing geometry, contrast, color, etc., the library also contains a variety of nature scenes for determining subjective picture quality. Uncompressed long moving sequences with nature scenes and artificial test patterns are also included. For development work, a pixel shift function has been added to enable the user to move picture elements in the test pattern without loading them beforehand.

Deep color (30/36 bit), xvYCC support

Since the release of HDMI version 1.3, color depth has become a decisive quality factor of display equipment. Deep-color support, i.e. color depth values beyond 10 bit (12 bit), is becoming a standard feature of both interfaces and flat panel displays. Bit clipping enables the AV signal generator to output not only full 36-bit RGB payout but also any lower color resolution.

xvYCC or extended gamut YCC in line with IEC 61966-2-4 is especially used in TV sets to increase the dynamic range of the available color space by a factor of 1.8. The R&S®DVSG offers special test signals to check the support and implementation at the terminal equipment end.

User-selectable variation of interface parameters and signal amplitude

For testing the different operating modes at the analog and digital interfaces, the interface parameters can be easily changed via the graphical user interface of the R&S®DVSG. The pin assignment, format and analog signal amplitude, for example, can be set for analog interfaces. Different protocol parameters such as DVI mode and HDCP can be configured for digital interfaces and the HDMI interface in particular.

Multichannel audio generation

Audio features are just as decisive as visual data processing and presentation. The R&S®DVSG can be used to measure audio parameters such as total harmonic distortion, frequency response, signal-to-noise ratio and lip synchronicity. Audio signals can be generated in different ways: file-based playback, internal sinewave generator function and external feed via S/P-DIF input.

Comprehensive test signal libraries available

- Multi-Motion test sequences for TV resolutions (up to 1080p)
- Universal test pattern with TV and PC resolution (up to 1080p or WUXGA)
- EBU test pattern in line with TECH 3325 with TV resolution (up to 1080p)
- Nature scenes with TV and PC resolution (up to 1080p or WUXGA)

Multi-Motion test sequences from Rohde & Schwarz



Multi-Motion test sequences for TV resolutions (up to 1080p)
The sequences allow the reproducible assessment of motion blur, deinterlacing, overdrive and film detection. Special scales next to the test elements in the picture permit the user to draw comparisons.

Universal test pattern

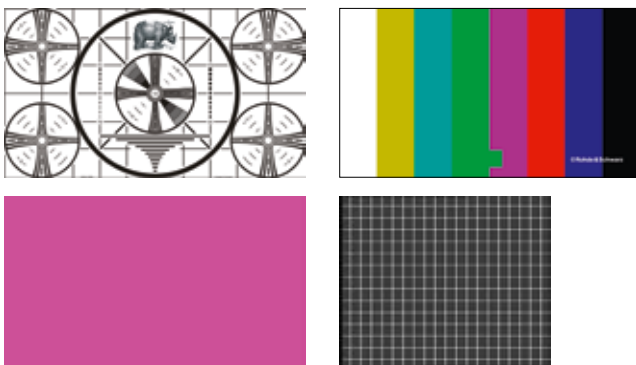

Universal test pattern with TV and PC resolution (up to 1080p or WUXGA)
The test patterns contain special test lines as well as static and moving elements. They allow test applications such as EMC, lip sync and VITS measurements. Examples of test patterns include monoscope pattern, moving colorbar, zone plate, various CCIR test patterns, basic colors, etc.

EBU test pattern

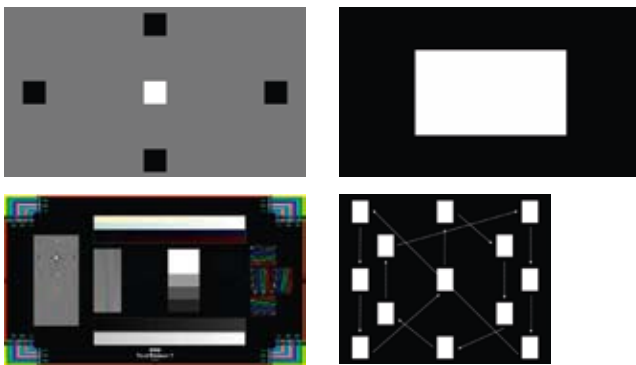

EBU test pattern in line with TECH3325 with TV resolution (up to 1080p)
EBU TECH3321 titled "EBU Guidelines for Consumer Flat Panel Displays (FPDs)" describes how broadcast programs should appear on displays. These guidelines define the technical parameters and the required measurement methods. Reference is made to test sequences from EBU TECH3325.

Nature scenes with TV and PC resolution



Nature scenes with TV and PC resolution (up to 1080p or WUXGA)
To enable subjective picture quality assessment, the AV signal generator library provides a variety of nature scenes as static and moving sequences. These scenes usually pose problems for displays.

Output of compressed live signals

R&S®DVSG-B30 AV signal player option

Playing of signals with special characteristics: blocking, motion, scene blending

The AV signal player option enables the R&S®DVSG to generate live sequences with scene cuts, movements, complex pictures, blocking and other compression artifacts so that users can test the processing of signals that are typically encountered in the use of display equipment. Tests of this type are particularly important for R&D and for test houses. In R&D, they make it possible to optimize the display equipment for use under realistic conditions. Test houses can use them to thoroughly check the quality of display equipment. Because the AV signals are generated on the basis of the MPEG-2 transport stream format, any live signals recorded worldwide (e.g. including H.264-coded contents) can be employed. Critical conditions of use can thus be reproduced very easily for optimizing display technology and for troubleshooting.

Test signal libraries delivered with the AV signal player option

- ▮ Critical live sequences
- ▮ Wide variety of additional test signals

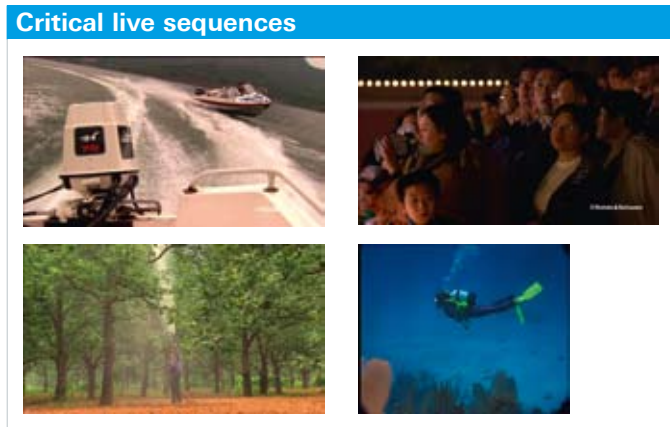

The live sequences contain critical elements that enable the subjective assessment of deinterlacing, deblocking or noise reduction. The large variety of test sequences with different scenarios makes it possible to subject the picture processing unit to stress tests.

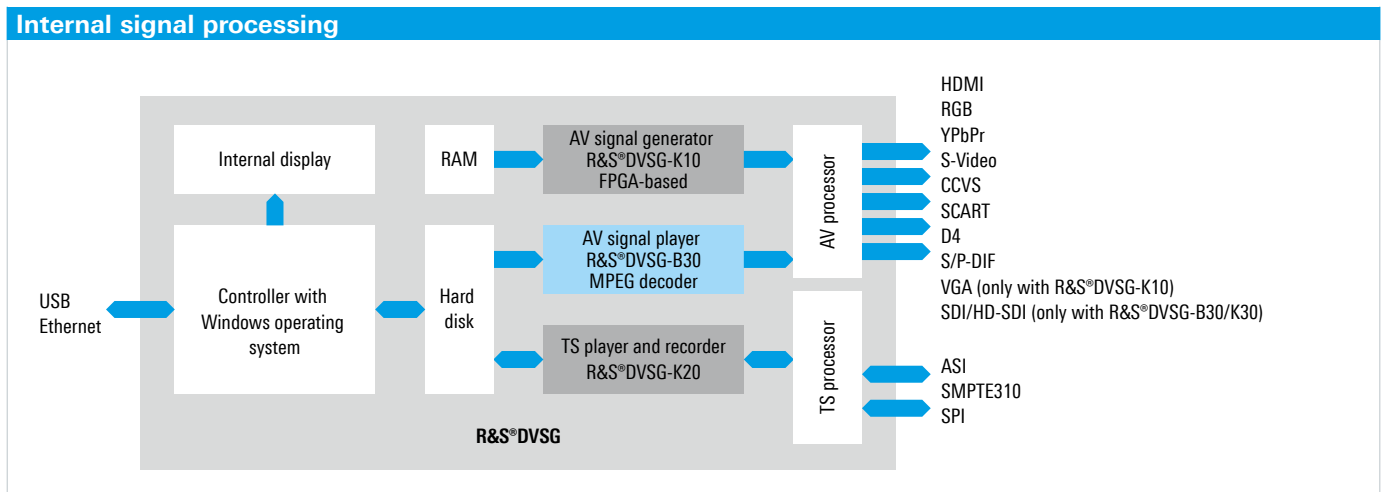

Recording and playing of transport streams

R&S®DVSG-K20 TS player and recorder option

When equipped with the R&S®DVSG-K20 transport stream (TS) player and recorder option, the R&S®DVSG is a valuable R&D tool for testing set-top boxes, multiplexers, decoders and their components such as chips and boards. In production environments and in the lab, it can be combined with a test modulator to function as a signal source for testing set-top boxes and TV sets. In addition, it is ideal for network operators and program providers as a favorably priced tool for recording live signals and as a reference signal source for setting up networks.

Seamless playback of transport streams on SPI, ASI and SMPTE310M interfaces

Seamless transport streams generate video/audio test signals that are used for continuous testing of receive equipment. The video/audio content is reproduced seamlessly so that a signal is always present at the interfaces.

The transition from the end back to the beginning of the sequence is seamless. With regard to transport streams, this means that all time stamps in the stream are calculated and inserted in realtime. In addition, the video and audio signals in the Rohde&Schwarz transport stream libraries are cut in a way that even a video decoder in the TV set will not detect any breach of syntax. This approach ensures that errors are clearly assigned to the DUT and not to the signal source.

Comprehensive transport stream libraries for all relevant broadcast standards

These transport stream libraries support the development of protocol stacks for the various broadcast standards and the implementation of the decoder chipsets integrated into the terminal equipment. Specific baseband streams for transmission standards such as DVB, ATSC, ISDB-T/TB, MediaFLO™, CMMB and ATSC-M/H are optionally available. The existing libraries are continuously being expanded, and new standards are being implemented as quickly as possible.

External R&S®DV-ASC advanced stream combiner software for customer-specific test signals

If signals are needed that are not contained in the libraries, the R&S®DV-ASC advanced stream combiner software can be used. The advanced stream combiner is a very convenient tool for generating MPEG-2 transport streams. The user selects the wanted video, audio and data contents. The software adds all the data required in order to generate an error-free and standard-compliant MPEG-2 transport stream. All data added by the software can be modified if needed. Customers can use their own video, audio and data contents.

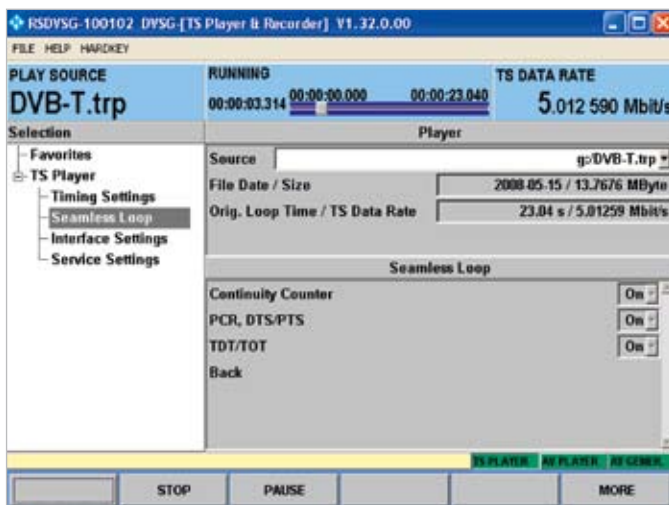

The R&S®DVSG-K20 features a seamless TRP function for uninterrupted playback of transport streams.

Standard-compliant output via all common video and audio interfaces

Modern display equipment has a large number of different AV interfaces and can handle an almost unimaginable number of video formats. The R&S®DVSG combines these interfaces and video formats in a single box:

Digital video interfaces

- ▮ HDMI/DVI
- ▮ SDI/HD-SDI (only via R&S®DVSG-B30 AV signal player)

Analog video interfaces

- ▮ RGB/YPbPr
- ▮ VGA (only via R&S®DVSG-K10 AV signal generator)
- ▮ S-Video
- ▮ CCVS
- ▮ SCART
- ▮ D4

Digital audio interfaces

- ▮ HDMI
- ▮ SDI/HD-SDI (embedded audio)
- ▮ S/P-DIF optical

Analog audio interfaces

- ▮ SCART (stereo)
- ▮ RCA (L/R)

The R&S®DVSG supports diverse formats from SD to HD for the analog and digital interfaces, ranging from PAL and NTSC signals (CCVS) to 1080p HD signals for the HDMI interface.



Rear view of the R&S®DVSG showing interfaces.

Fast and easy testing

AV signals simultaneously available at the analog and digital interfaces

With only a few exceptions, the AV signals are simultaneously present at all interfaces, provided that the selected formats are compatible with the interface type. This allows quick testing of the DUT because no switchover is required on the R&S®DVSG.

Intuitive and efficient operation

The R&S®DVSG is easy and intuitive to operate. In addition to local operation via rotary knob and keypad, users can opt for connecting an external mouse and a keyboard via the USB port. The R&S®DVSG can also be operated via Remote Desktop and a computer network. Firmware updates or file transfers can be performed easily because the instrument runs under Windows XP.

Ideal test signal generator for automated and remote-controlled test sequences

The VXI11 remote-control interface allows fast and reliable remote control of the R&S®DVSG signal generator. The generator can be conveniently integrated into test systems via VISA drivers. The command set of the R&S®DVSG is in line with the Standard Commands for Programmable Instruments (SCPI) industry standard. Remote control is therefore clear and simple.



Application

Development and quality assurance of TV displays

Display measurement with the R&S®DVSG in various development and quality assurance applications

The development and quality assurance of TV displays is divided into the following four main categories:

Measurement of the elementary display parameters

Basic parameters are tested that mostly depend on the display equipment panel.

▷ [page 11](#)

Test of the picture processing unit

The behavior of the picture processing unit of the display equipment and the panel is testing by feeding in moving pictures.

▷ [page 12](#)

Test of the audio processing unit

The audio functions and the sound quality of the TV set are tested with regard to implementation and quality.

▷ [page 13](#)

Functional and stress test

Functional tests of the supported interfaces, including protocol and aspect ratio tests, as well as simple Go/NoGo tests are carried out.

▷ [page 14](#)

Application: test of TV displays

Basic display parameters

- ▮ Dynamic range
- ▮ Contrast
- ▮ Gamma
- ▮ Gamut
- ▮ Uniformity
- ▮ Dependence on viewing angle
- ▮ etc.

Functional and stress tests

- ▮ Functional test of all interfaces
- ▮ Variation of interface and signal parameters

Picture processing

- ▮ Scaling
- ▮ Deinterlacing (3:2/2:2 pulldown)
- ▮ Motion artifacts (motion blur, false contouring)



Audio processing

- ▮ Amplitude
- ▮ Frequency response
- ▮ Signal-to-noise ratio
- ▮ Total harmonic distortion
- ▮ Crosstalk
- ▮ Lip synchronicity
- ▮ etc.

Measurement of the elementary display parameters

The R&S®DVSG is an important building block of a test setup for measuring brightness, color, contrast and angle of view. Using appropriate test patterns that are played via the R&S®DVSG-K10 AV signal generator option, a color meter or spectrometer can determine these display-specific parameters.

The brightness of the picture, for example, determines how well the TV picture can be perceived under daylight conditions. The perception quality (gray scale linearity) is determined by means of completely white or partially white areas in the test pattern which exhibit varying intensity. The color measurement usually includes the determination of the primary colors R, G, B and of the white point.

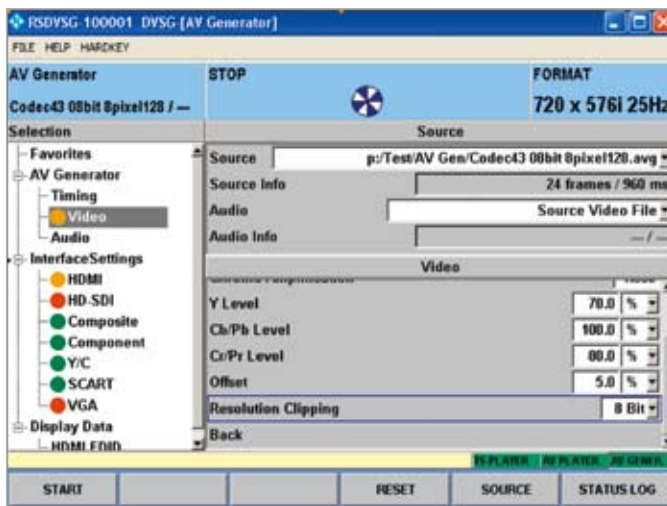

Gray scale linearity measurement: test pattern and GUI with level variation.

Application example

The TV set displays the test patterns generated by the R&S®DVSG, e.g. for determining contrast and gamut.

A color meter or a spectroradiometer is used for measuring the display.



The R&S®DVSG outputs the test patterns via the digital or analog interfaces.

Test of the picture processing unit

Almost all state-of-the-art TV sets support PAL and NTSC SD formats. In addition, the number of HDTV sets with resolutions of up to 1920 × 1080p is constantly increasing. Refresh rates of 50/60 Hz have been common for a long time. However, there are also many new timing standards such as 24 Hz for contents from movies or their TV spin-off in 2:2/3:2 pulldown.

Designing the picture processing unit is one of the most complicated tasks when developing a state-of-the-art TV set. The quality of the TV picture depends above all on the capability of the picture processing unit to adapt the incoming video and audio data to the format and the response time of the display. Conventional static test patterns have only limited usefulness because they do not put enough pressure on the algorithm of the picture processing unit to detect errors or weak points.

The R&S®DVSG provides Multi-Motion test sequences from Rohde & Schwarz, which allow the picture processing unit to be thoroughly tested by means of critical picture contents. For example, there are special moving sequences that include both conventional interlaced content and progressive movie content (3:2 pulldown). Other sequences permit the reproducible determination of motion blur, e.g. using horizontal and vertical text moving at different speeds. Special live sequences allow the subjective assessment of overall picture quality.

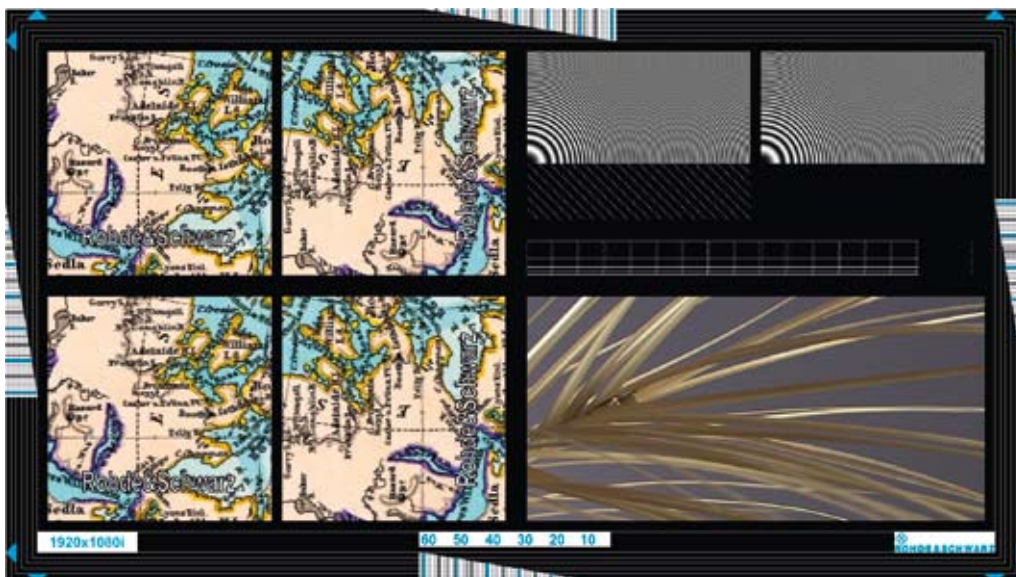

This Multi-Motion test sequence helps to precisely analyze the deinterlacing quality of the picture processing unit.

Test of the audio processing unit

Especially in the case of HDMI, audio information is transmitted in addition to the SD and HD video content. The R&S®DVSG provides ample audio generator functionality for checking the sound quality of the TV receiver. It also offers file-based playback and external feed via the S/P-DIF interface as well as an internal user-configurable audio generator.

The new test signals make it possible to measure total harmonic distortion, frequency response and signal-to-noise ratio. For measurements, audio content can be played on up to eight audio channels so that even surround sound systems can be tested. The combination of the R&S®DVSG with audio analyzers such as the R&S®UPV allows detailed quality assessment. The synchronization of picture and sound can be fully checked using test sequences (lip sync test).



Audio test setup consisting of the R&S®DVSG, a TV set and the R&S®UPV.

Functional and stress test

EMC applications in particular require universal testing of all audio and video interfaces of consumer equipment. As an example, the CISPR20 standard stipulates that electronic equipment must be checked for immunity to disturbance in all possible operating modes and that TV sets may not present any picture or sound defects.

The focus with digital interfaces is on protocol-specific parameters. The HDMI interface in particular features a wide variety of parameters that are required for smooth communications, including high definition content protection (HDCP), extended display identification data (EDID) and DVI compatibility. The R&S®DVSG is able to check all these functions.

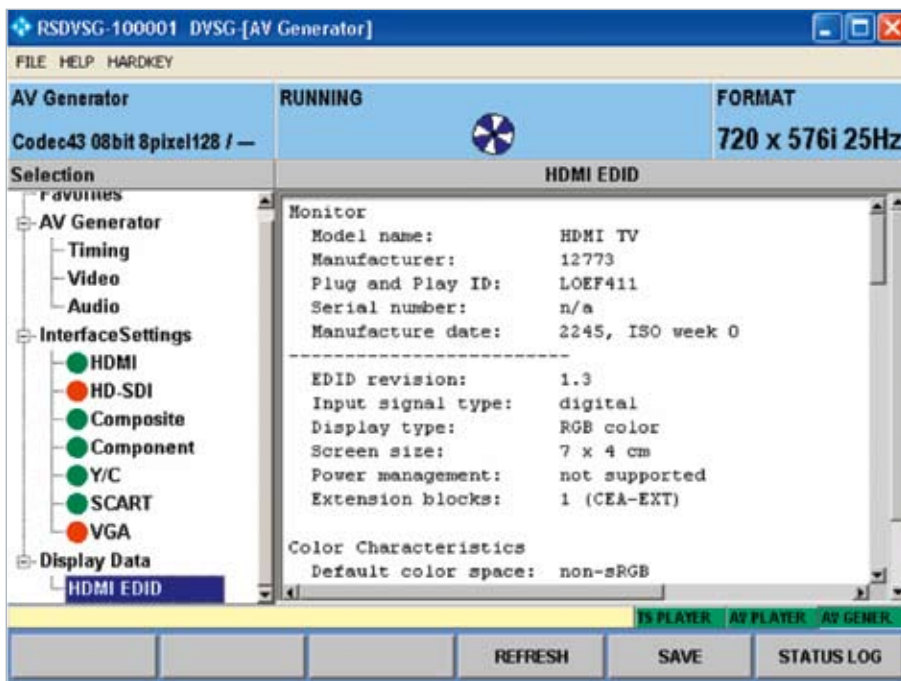

Presentation of the EDID data of the TV display on the R&S®DVSG.

Ordering information

Designation	Type ¹⁾	Order No.
Base unit		
Digital Video Signal Generator	R&S®DVSG	2113.0008.02
including: quick start guide, operating manual with firmware on CD, power cable		
AV signal player and AV signal generator options		
AV Signal Generator (including pattern library)	R&S®DVSG-K10	2113.0314.02
AV Signal Generator Extension ²⁾ (hardware expansion and pattern library for outputting long moving sequences)	R&S®DVSG-B10	2113.0208.02
AV Signal Player	R&S®DVSG-B30	2113.0237.02
SDI/HD-SDI Output (R&S®DVSG-B30 required)	R&S®DVSG-K30	2113.0337.02
TS player and recorder options		
TS Player and Recorder	R&S®DVSG-K20	2113.0320.02
Stream Libraries		
HDTV Sequences	R&S®DV-HDTV	2085.7650.02
H.264 Stream Library	R&S®DV-H264	2085.9052.02
DVB-H Stream Library	R&S®DV-DVBH	2085.8704.02
Test Card M Sequences	R&S®DV-TCM	2085.7708.02
ISDB-T Stream Library	R&S®DV-ISDBT	2085.9146.02
MediaFLO™ Streams	R&S®SFU-K222	2110.2968.02
ISDB-Tb Transport Streams	R&S®SFU-K224	2110.4777.02
CMMB Transport Streams ²⁾	R&S®SFU-K225	2112.3649.02
ATSC-M/H Transport Streams ²⁾	R&S®SFU-K226	2110.3812.02
TS creation tool		
Advanced Stream Combiner (dongle for USB interface)	R&S®DV-ASC	2085.8804.03
Rack installation		
19" Adapter (R&S®DVSG with spare slot)	R&S®ZZA-T34	1109.4464.00
19" Adapter (R&S®DVSG with second instrument)	R&S®ZZA-T33	1109.4458.00
Recommended extras		
Keyboard with USB Interface (US keyboard)	R&S®PSL-Z2	1157.6870.04
Mouse with USB Interface, optical	R&S®PSP-B6	1134.8201.13
Printed operating manual (English)		2113.1862.12
Service options		
(Service options can only be ordered in connection with the purchase of an instrument.)		
Repair options		
One-Year Repair Service following the warranty period	R&S®RO2DVSG	please contact your local sales office
Two-Year Repair Service following the warranty period	R&S®RO3DVSG	please contact your local sales office
Four-Year Repair Service following the warranty period	R&S®RO5DVSG	please contact your local sales office
Calibration options		
Two-Year Calibration Service	R&S®CO2DVSG	please contact your local sales office
Three-Year Calibration Service	R&S®CO3DVSG	please contact your local sales office
Five-Year Calibration Service	R&S®CO5DVSG	please contact your local sales office

¹⁾ Option identification: R&S®DVSG-Bxxx = hardware option; R&S®DVSG-Kxxx = software option.

²⁾ Availability planned for September 2009.

The data sheet with complete technical specifications is available at PD 5213.9892.22 and www.rohde-schwarz.com.

Service you can rely on

- | Worldwide
- | Local and personalized
- | Customized and flexible
- | Uncompromising quality
- | Long-term dependability

About Rohde & Schwarz

Rohde & Schwarz is an independent group of companies specializing in electronics. It is a leading supplier of solutions in the fields of test and measurement, broadcasting, radiomonitoring and radiolocation, as well as secure communications. Established 75 years ago, Rohde & Schwarz has a global presence and a dedicated service network in over 70 countries. Company headquarters are in Munich, Germany.

Environmental commitment

- | Energy-efficient products
- | Continuous improvement in environmental sustainability
- | ISO 14001-certified environmental management system

Certified Quality System
ISO 9001

Rohde & Schwarz GmbH & Co. KG

www.rohde-schwarz.com

Regional contact

- | Europe, Africa, Middle East
+49 89 4129 137 74
customersupport@rohde-schwarz.com
- | North America
1 888 TEST RSA (1 888 837 87 72)
customer.support@rsa.rohde-schwarz.com
- | Latin America
+1 410 910 79 88
customersupport.la@rohde-schwarz.com
- | Asia/Pacific
+65 65 13 04 88
customersupport.asia@rohde-schwarz.com