

Products: Signal Analyser FSIQ26/FSP13/FSU8/FSQ26

Out of Band Spurious Measurement for Bluetooth Modules

Application Note

This application notes describes the out of band Spurious emission measurement for Bluetooth modules as defined in the RF Test Specification for Bluetooth V0.91. It includes a program demonstrating conducted measurements performed remotely using a spectrum analyser FSIQ, FSP, FSU or FSQ.



Contents

1	Overview	3
2	Hardware and Software Requirements	4
	Hardware Requirements	4
	Software Requirements	4
3	Test Setup	5
	Test Modes and Stimulus Signals	6
4	Test Procedure	7
5	Test Specification	12
6	Test Program	14
7	Additional Information	15
8	Ordering information	15

1 Overview

This application notes describes the out of band Spurious emission measurement for Bluetooth modules as defined in the RF test specification for Bluetooth V0.91. It includes a program demonstrating conducted measurements performed remotely using a spectrum analyser FSIQ, FSP or FSU.

The performance of the host or device can be influenced by Radio Frequency Interference (RFI) from the Bluetooth module, especially if the module generates its own out of band RF emissions.

To be certified, a Bluetooth module must have passed the out of band spurious emission tests, and ensure out of band spurious emission generated by the Bluetooth module is within applicable limits.

Out of band spurious emissions are unwanted emissions immediately outside the channel bandwidth resulting from the modulation process and non-linearity in the transmitter.

2 Hardware and Software Requirements

Hardware Requirements

The software runs on a PC with

CPU	Pentium 133MHz or better
RAM	64 MBytes or more
MONITOR	VGA color monitor
IEC/IEEE BUS	IEC/IEEE bus interface Rohde & Schwarz IEEE-488.2 bus interface PS-B4 , 1006.6207.04, or National Instruments AT-GPIB/TNT or GPIB-PCMCIA card

It supports following instruments named below:

- **FSIQ, FSP, FSU** or **FSQ** spectrum analyzer.

Software Requirements

WINDOWS 9X/NT/2000/XP	Microsoft operating system
NI-488.2 v1.6 (or above)	IEC/IEEE - bus driver from National Instruments. See http://www.natinst.com for latest revision.
NI-VISA v2.01 (or above)	VISA driver from National Instruments. See http://www.natinst.com for latest revision.
Optionally:	
NI-Measurement Studio	Includes LabWindows/CVI v6.x

3 Test Setup

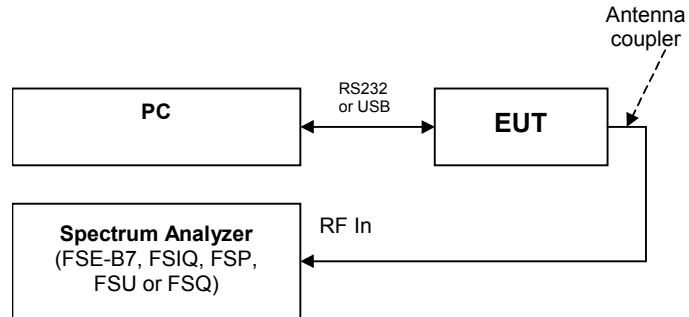

Fig. 1 Setup for out of band spurious emission measurement

The Equipment Under Test (EUT), a Bluetooth module is switched to a test mode in which it generates the transmitter signal required for the test. The analyzer is configured by a test program (for example the demoprogram, which runs on a PC in Fig. 1), which then starts a measurement. The program fetches the results and evaluates them. If necessary, a Bluetooth stimulus signal can be supplied by a SMIQ signal generator. All transmitter signal measurements can be carried out using a Rohde & Schwarz spectrum analyzer FSE with option FSE-B7, FSIQ, FSP, FSU or FSQ and a controller.

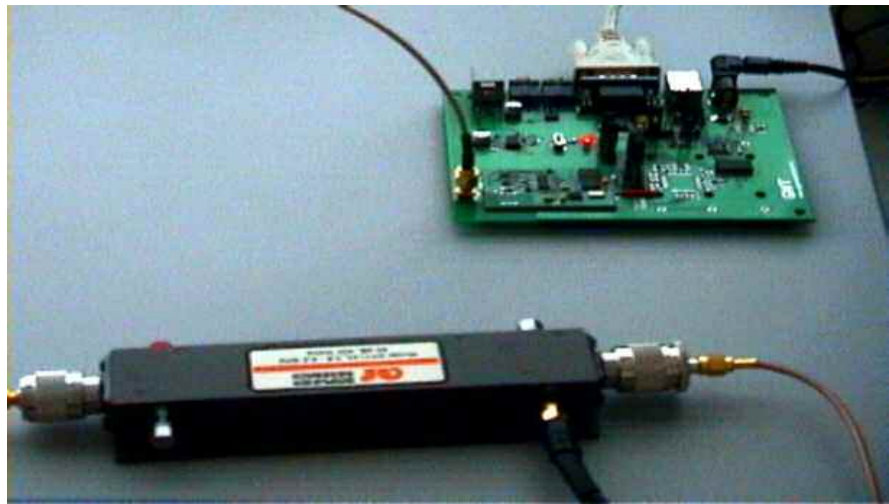

Fig. 2 The Bluetooth module connected to a directional coupler during conducted emission tests.

Test Modes and Stimulus Signals

According to test specifications the initial conditions are:

1	The EUT must be switched to loopback mode. This can be caused by the test equipment setting up a call with the EUT.
2	Hopping is OFF
3	The tester transmits DH1 packets with the PRBS 9 as payload to the EUT.

Simple Bluetooth continuous waveform signals can be generated with a SMIQ signal generator or a combination of SMIQ and AMIQ I/Q modulation generator. On the SMIQ, all parameters for the Bluetooth standard (modulation mode, deviation, filtering) can be loaded at a keystroke. Use the Rohde & Schwarz software package WinIQSIM to generate standard conforming packet data. For detailed instructions see Application Note 1GP38.

Note: Signalling is not possible with a SMIQ signal generator.

4 Test Procedure

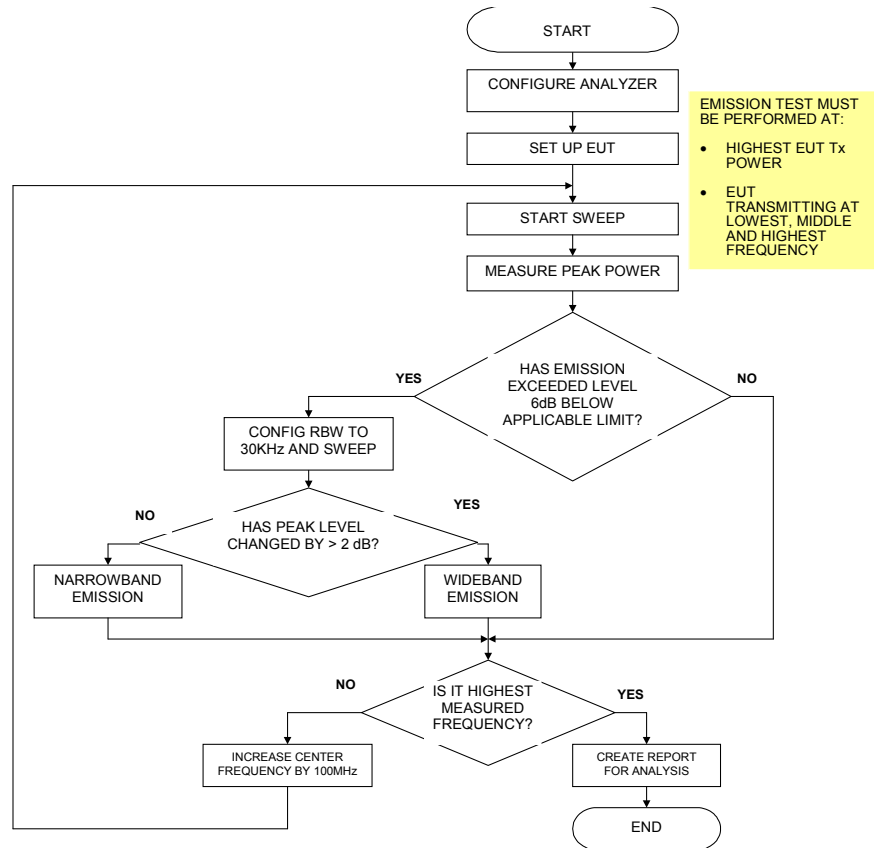

Fig. 3 General flow chart for the out of band spurious emission measurement according to ETS 300-328

According to the ETS 300-328 for EUT with a passive antenna, the conducted measurement for the out of band spurious emissions ranges from 30 MHz to 12.75 GHz.

Radiated tests require signalling via a cable connection and a frequency sweep from 30 MHz to 12.75 GHz.

For EUT without a passive antenna, the signalling is established via airlink and the radiated test sweep from 30 MHz to 12.75 GHz.

The measurement procedure for both conducted and radiated tests is as follows:

- 1) Transmitter operating at maximum power.
- 2) The EUT operates at its Highest Receiving Frequency FRX (2480 MHz) and Lowest Transmitting Frequency FTX (2402 MHz).

Out-of-Band Spurious Measurement

- 3) The spectrum analyzer is configured as follows:

Resolution bandwidth	100 kHz
Video bandwidth	100 kHz
Span	100 MHz
Detector Mode	Peak
Mode	Maxhold
Amplitude	Middle of instrument's range
Sweep time	1 second, single sweep
Center frequency	80 MHz

- 4) The spectrum beyond the operating range (2402-2480 MHz) will be scanned for emission.
- 5) If emissions exceed the level 6 dB below the applicable limit, the resolution bandwidth is switched to 30 kHz and the span adjusted accordingly. If the level does not change by more than 2 dB, the emission is wideband and its value recorded in the test report. Only peak values outside the operating frequency range (2400 – 2483.5 MHz) are recorded.
- 6) Increase analyzer center frequency by 100 MHz.
- 7) Repeat steps 4) to 6) until the highest frequency is reached.
- 8) For an EUT supporting power control, steps 2) to 7) are performed at minimum output power.
- 9) Repeat steps 1) to 8) except 2) while the EUT transmits at
- the mid operating frequency
 - the highest operating frequency
- 10) Repeat steps 3) to 7) for the EUT in 'standby mode' with the following sweep time settings.

The sweep time for the 'standby mode' measurement is derived from the inquiry scan interval and duration of the EUT. The sweep time corresponds to the inquiry scan duration. The number of sweeps chosen has to cover a complete inquiry scan interval. If the sweep time is too short to cover the span, the span can be split into 2 or more parts. Alternatively page scan can be used.

Out-of-Band Spurious Measurement

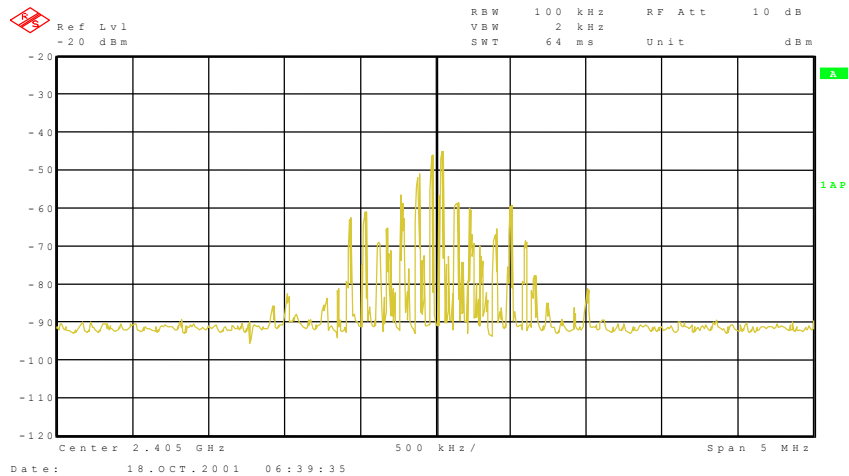

Fig. 4 The diagram shows the generation of Bluetooth signals from the EUT

For FCC Section 15.247 for spurious emission, the measurement procedure for conducted emission tests is defined as follows:

- 1) Transmitter operates at maximum power.
- 2) The EUT operates at Lowest Receiving Frequency FRX (2480 MHz) and Highest Transmitting Frequency FTX (2402 MHz).
- 3) The spectrum analyzer is set up as follows:

Center Frequency	2441 MHz
Resolution Bandwidth	100 kHz
Video Bandwidth	300 kHz
Vspan	240 MHz
Detector Mode	Peak
Mode	Maxhold
Sweep Time	≥12 sec, single sweep

- 4) Start the sweep.
- 5) Peak value of the sweep is recorded as Pref.
- 6) The setting of the spectrum analyzer is changed as follows:

Resolution Bandwidth	100 kHz
Multiple spans covering frequ. ranges	30 kHz to 25 GHz
Video Bandwidth	300 kHz
Detector Mode	Peak
Mode	Maxhold
Sweep Time	Coupled

- 7) Start the sweep.
- 8) The sweep peak value is recorded as PPK. Only peak values outside the operating frequency range (2400 – 2483.5 MHz) are recorded.
- 9) Switch the analyzer to next span interval.

Out-of-Band Spurious Measurement

- 10) Repeat steps 16) to 19) until the center frequency > 25GHz.
- 11) Repeat steps 12) to 20) for EUT operating at Highest Receiving Frequency FRX (2480 MHz) and lowest transmitting frequency FTX (2402 MHz).

For the FCC Section 15.247 for spurious emission, the measurement procedure for radiated emission tests is defined as follows:

- 1) Transmitter operates at maximum power.
- 2) The EUT operates at lowest receiving frequency FRX (2480 MHz) and highest transmitting frequency FTX (2402 MHz).
- 3) The spectrum analyzer settings for frequencies below 1 GHz are defined below:

Resolution bandwidth	100 kHz
Video bandwidth	300 kHz
Multiple scans chosen according to the restricted bands listed in the EXPECTED OUTCOME FCC Part 15.247	
Detector Mode	Quasi-Peak Detector
Mode	Maxhold
Sweep time	1 second, single sweep

- 4) Start the sweep.
- 5) The sweep peak value is found and compared with the EXPECTED OUTCOME FCC Part 15.247.
- 6) Switch the analyzer span to the next range.
- 7) Repeat 25) to 27) until all spans <1 GHz are covered.
- 8) The spectrum analyzer settings for frequencies above 1 GHz are defined below:

Resolution bandwidth	1 MHz
Video bandwidth	1 MHz
Multiple scans chosen according to the restricted bands listed in the EXPECTED OUTCOME FCC Part 15.247	
Detector Mode	Average Detector
Mode	Maxhold
Sweep Time	Coupled, single sweep

- 9) Start the sweep.
- 10) The sweep peak value is found and compared with the EXPECTED OUTCOME FCC Part 15.247.
- 11) Switch the analyzer span to the next range.
- 12) Repeat 30) to 32) until all spans <1 GHz are covered.

Out-of-Band Spurious Measurement

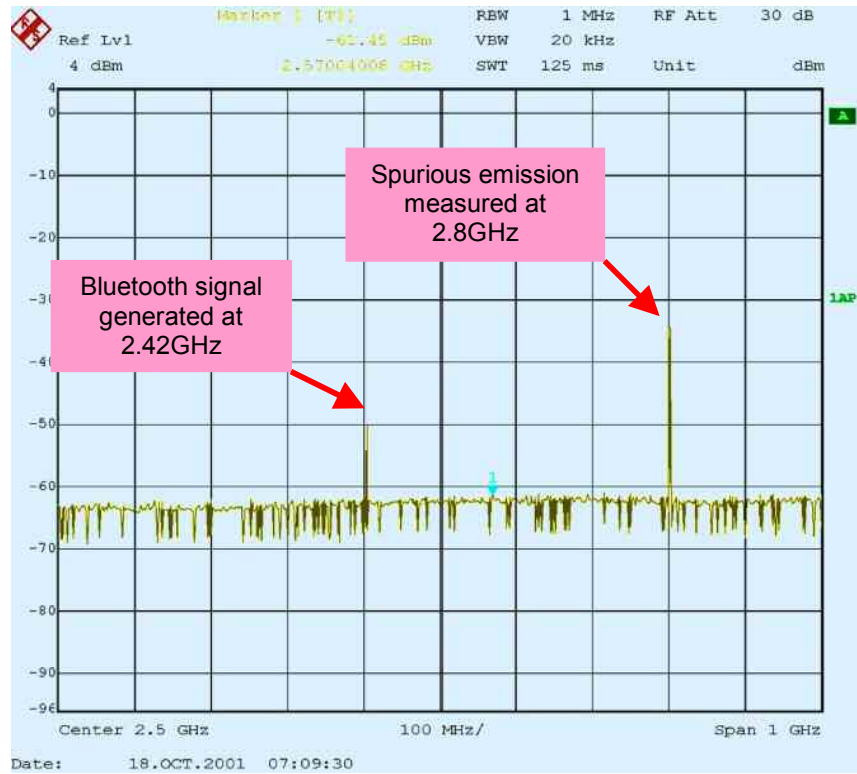

Fig. 5 Bluetooth signal and spurious emission from the spectrum analyzer

5 Test Specification

Bluetooth is a cable replacement technology that eliminates the need for numerous cable attachments for connecting computers, mobile phones, mobile computers and handheld devices, using a short-range wireless connection.

The ETS 300 328 (Europe) computing and industrial specification defines 2-distance coverage: 10m and 100m. The RF output for 10m range is 0dBm (1mW), and for 100m range, it is 20 dBm (100mW).

The technology is capable of both voice and data transmission. On the data channel, asymmetric mode supports a maximum bit rate of 723.2Kbps with 57.6Kbps in the return path. In symmetric mode, the specification is capable of 433.9Kbps bit rate on each channel.

Bluetooth operates in the unlicensed Industrial, Scientific and Medical (ISM) band at 2.4Ghz to 2.48Ghz, using frequency hopping spread spectrum, up to 1600 Hops/sec. The signal hops among 79 frequencies at 1MHz intervals to give a high degree of interference immunity.

As the band becomes more widely used, radio interference will increase. Radiated or conducted interference can come from virtually anywhere. Although it is important to limit the in-band interference, the bluetooth module must also be verified to ensure that the out of band spurious emission will not have any influence on the device or its environment.

Out of band spurious emissions are unwanted emissions immediately outside the channel bandwidth resulting from the modulation process and non-linearity in the transmitter.

All values as measured must fulfill the following conditions.

ETS 300 328 (Europe)

Limits for Narrowband Spurious Emissions

Frequency Range	Limit when operating	Limit in standby
30MHz – 1GHz	-36 dBm	-57 dBm
Above 1GHz – 12.75GHz	-30 dBm	-47 dBm
1.8GHz – 1.9GHz	-47 dBm	-47 dBm
5.15GHz – 5.3GHz	-47 dBm	-47 dBm

Out-of-Band Spurious Measurement

Limits for Wideband Spurious Emissions

Frequency Range	Limit when operating	Limit when in standby
30MHz – 1GHz	-86 dBm/Hz	-107 dBm
Above 1GHz – 12.75GHz	-80 dBm/Hz	-97 dBm
1.8GHz – 1.9GHz	-97 dBm/Hz	-97 dBm
5.15GHz – 5.3GHz	-97 dBm/Hz	-97 dBm

FCC Part 15.247 (USA) :

Conducted

$P_{ref} - P_{PK} \geq 20\text{dB}$, as measured in the frequency range 30MHz to 25GHz, excluding the operating frequency band.

Radiated

Limits for Wideband Spurious Emissions

Frequency Range	Field Strength ($\mu\text{Volts / meter}$)	Measurement Distance (meters)
30MHz – 80MHz	100	3
88MHz – 216MHz	150	3
216MHz – 960MHz	200	3
960MHz – 2500MHz	500	3

6 Test Program

This application note includes a program for performing an out of band spurious conducted measurements with Bluetooth signals according to the test specification in the preceding chapter. The program can be installed by executing **BTObS v1.xx.MSI**. Start the program by executing **BTObS.EXE**.

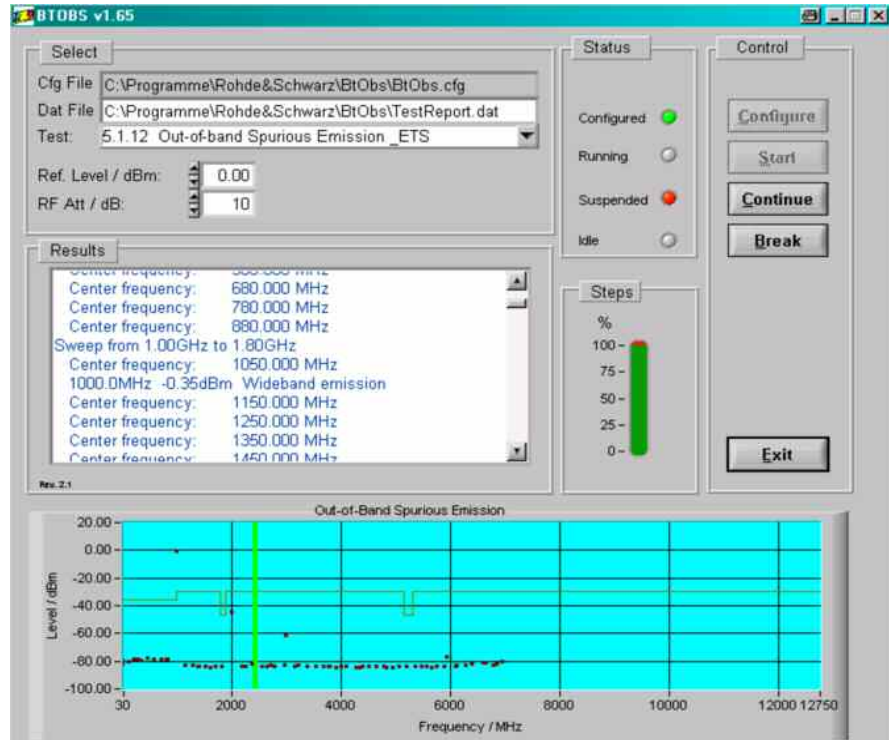

Fig. 6 BtObs Test Program

After selecting **DAT FILE** (name of test data file), **TEST** (ETS or FCC), **REF LEVEL** and **RF ATTENUATION** press configure to set up the instruments accordingly. The test run is initiated with **START**. The user may stop test sequence at any time with **BREAK**. The program stops occasionally to enable the user to change the Bluetooth TX frequency settings, allowing test sequence restart with the **CONTINUE** button. The graphic display shows the limit line of the ETS conducted test and the measured maximum levels in the 100MHz spans.

The included source code requires LabWindows/CVI v6.0 (Measurement Studio) and above for compilation.

7 Additional Information

Please contact TM-Applications@rohde-schwarz.com for comments and further suggestions.

8 Ordering information

To perform the transmitter measurements presented in this application note, a FSE spectrum analyzer with option FSE-B7, FSIQ, FSP, FSU or FSQ signal analyzer is required.

IQ Modulator		
AMIQ-04	16 MSamples	1110.2003.04
Vector Signal Generator		
SMIQ02	(300 kHz to 2.2 GHz)	1084.8004.02
SMIQ02E	(300 kHz to 2.2 GHz)	1106.1806.02
SMIQ03	(300 kHz to 3.3 GHz)	1084.8004.03
SMIQ03E	(300 kHz to 3.3 GHz)	1106.1806.03
SMIQ06	(300 kHz to 6.0 GHz)	1084.8004.06
Spectrum Analyzer		
FSEA30	(20 Hz to 3.5 GHz)	1065.6000.30
FSEB30	(20 Hz to 7.0 GHz)	1066.3010.30
FSEK30	(20 Hz to 40 GHz)	1088.3494.30
FSEM30	(20 Hz to 26.5 GHz)	1079.8500.30
FSIQ3	(20Hz to 3.5GHz)	1119.5005.03
FSIQ7	(20Hz to 7 GHz)	1119.5005.07
FSIQ26	(20Hz to 26 GHz)	1119.6001.26
FSIQ40	(20Hz to 40 GHz)	1119.6001.26
FSP3	(9 kHz to 3 GHz)	1093.4495.03
FSP7	(9 kHz to 7 GHz)	1093.4495.07
FSP13	(9 kHz to 13 GHz)	1093.4495.13
FSP30	(9 kHz to 20 GHz)	1093.4495.30
FSU3	(20 Hz to 3.6 GHz)	1129.9003.03
FSU8	(20 Hz to 8 GHz)	1129.9003.08
FSQ3	(20 Hz to 3.6 GHz)	1155.5001.03
FSQ8	(20 Hz to 8 GHz)	1155.5001.08
FSQ26	(20 Hz to 26.5 GHz)	1155.5001.26
Options		
FSE-B7	Vector Signal Analyzer	1066.4317.02



ROHDE & SCHWARZ GmbH & Co. KG · Mühldorfstraße 15 · D-81671 München · P.O.B 80 14 69 · D-81614 München ·
Telephone +49 89 4129 -0 · Fax +49 89 4129 - 13777 · Internet: <http://www.rohde-schwarz.com>

This application note and the supplied programs may only be used subject to the conditions of use set forth in the download area of the Rohde & Schwarz website.