

R&S® CompactTSVP Platform Accessory Products

Digital control and coil-driver solution



75 Years of
Driving
Innovation



ROHDE & SCHWARZ

R&S® CompactTSVP Platform Accessory Products

At a glance

Being able to input and output digital signals is often a required standard functionality. Together with other auxiliary modules, R&S®TSVP-based equipment can also be affordably expanded with integrated accessories to yield multifaceted instruments that operate like a system.

Digital I/O signals make it possible to carry out a variety of control tasks when working with functional-test and in-circuit-test systems.

The R&S®TS-PIO3B and its accessories offer a number of ways to generate control signals and to provide transmission lines for integrating and connecting external test and measurement equipment – without having to use the PXI slots that might be needed for measurement tasks.

Fields of application from the real world prove what is possible:

- A contact switch for determining the "open/closed" fixture setting can be checked by using one input line
- Many devices under test (DUTs) must be switched to an input circuit provided for the test by means of steady-state digital signals; digital status signals must likewise be acquired on the DUTs and evaluated
- In the functional test, requirements for the discrete wiring of loads must be fulfilled. To achieve this, real loads such as load impedances, motors, valves or other actuators are often connected to the DUT output
- Relays can be used in different ways (as a power relay for supply voltage or as a transfer switch for RF signals). Applications must therefore be flexible enough to actuate the relay coils with the correct voltage and sufficient power
- To create a universal coil-driver interface, the 64 output lines of the digital I/O module have been equipped with the appropriate power outputs
- The speed for switching the relays or DUTs is often not a time-critical factor; a favorably priced module that can be driven via the internal CAN bus, e.g. the R&S®TS-PIO3B, is sufficient. PXI slots can be thus kept free for high-dynamic measurement and stimulus cards
- When digital control signals are distributed to various relays and DUT pins, a substantial time advantage and a more reproducible and documentable switching circuitry can be achieved by using standardized accessory parts

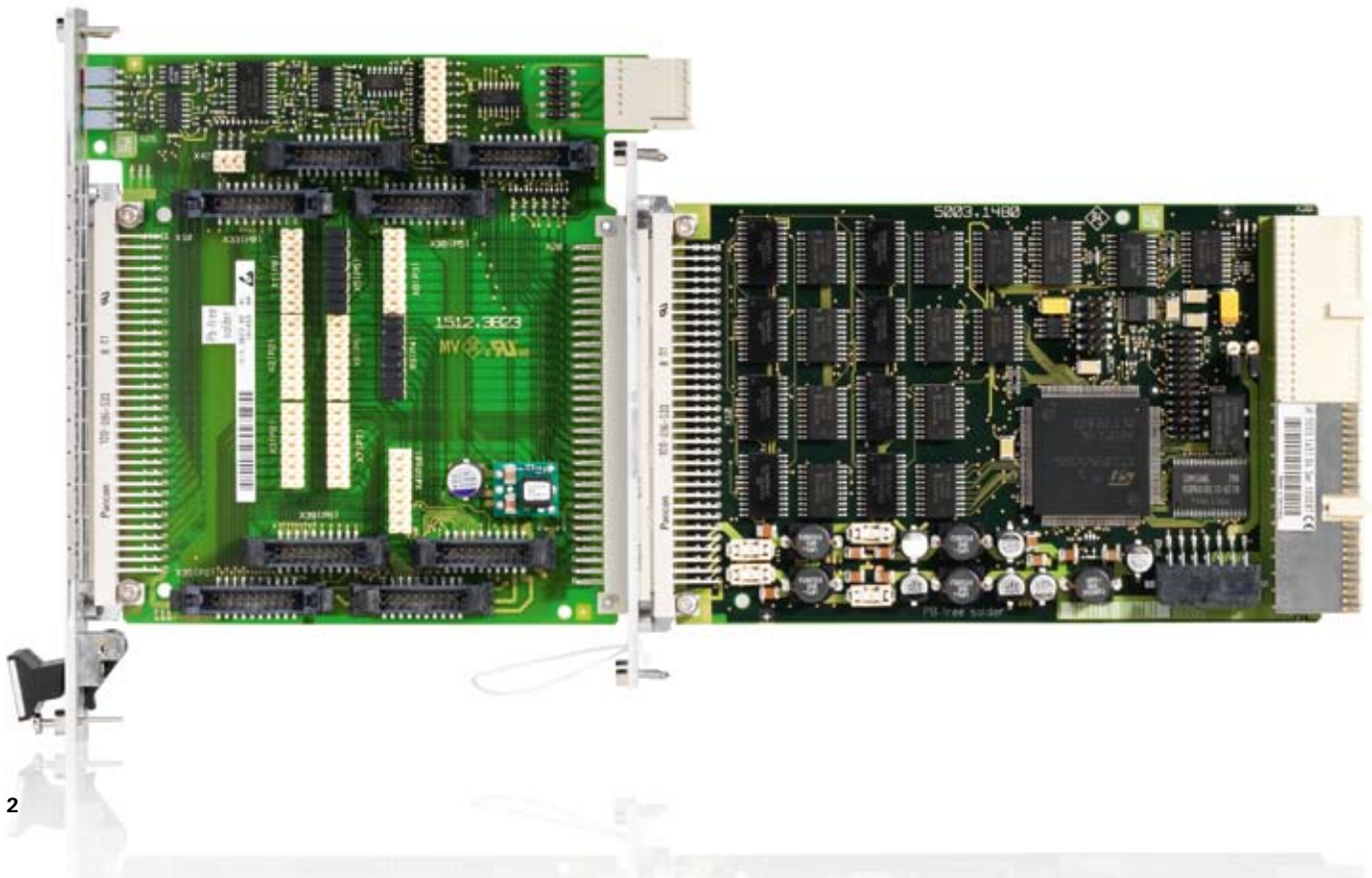

R&S® CompactTSVP Platform Accessory Products

Product overview

The accessories can be used to provide R&S®TSVP-based equipment with flexible, expandable functionality or to combine them with other measuring instruments to achieve extremely powerful hybrid test systems.

R&S®TS-PIO3B

- Powerful digital I/O module with 64 channels for reliable coil driver and signal routing, open-drain-driven outputs, utility ports for TTL I/O and analog inputs

▷ [page 4](#)

R&S®TS-PTRF

- Signal port and transmission module; flexible accessory module for transmitting and distributing signals from the R&S®TS-PIO3B or R&S®TS-PTR in very tight spaces

▷ [page 7](#)

R&S®TS-PXM1

- Switching extension module, 8 × 4 PDT, 30 V DC, 2 A; controlled via port connector to the R&S®TS-PTRF and the R&S®TS-PIO3B digital I/O module

▷ [page 9](#)

R&S®TS-PXB2

- Cost-efficient additional slots for accommodating R&S®TS-PIO3B digital I/O modules; backplane extension module, CAN bus, two slots, signal transmission to the set of D-Sub connectors at rear of instrument

▷ [page 10](#)

R&S®TS-PRIO4

- Rear I/O transmission module for seamless system integration of test fixtures; accessory module, routing signals from and to the R&S®TS-PIO3B digital I/O ports P5 to P7 or to the R&S®TS-PTR feedthrough module

▷ [page 12](#)

R&S®TS-PTR

- Signal transmission module; accessory module for routing signals from the rear via the R&S®TS-PRIO4 to the front, e.g. to a test fixture via the R&S®TS-PTRF

▷ [page 13](#)

R&S®TS-PIO3B

Digital I/O Module

Adapting DUTs to the industrial environment often requires auxiliary circuits that are ideally integrated in the test instrument. Simple digital control signals for triggering or monitoring DUTs and for controlling additional relays for RF or high-current applications with universal coil drivers play a major role here.

Flexible digital I/O module with 64 channels

The R&S®TS-PIO3B is a versatile digital I/O module with 64 channels that can be operated on all CAN bus slots both in the R&S®CompactTSVP and in the R&S®PowerTSVP.

The R&S®TS-PIO3B offers eight ports with eight digital I/O lines each that have MOSFET output drivers. The circuitry is designed to drive RF relays with all common control voltages. The high current-carrying capacity makes the module a universal coil driver.

Additionally, a further 8-bit-wide TTL port is integrated. For easily measuring voltages, the R&S®TS-PIO3B has eight analog inputs that can be monitored via a 10-bit A/D converter. An SPI interface offers the capability to control external SPI modules. To simplify the supply of power to DUTs or voltage dividers, the supply voltages are provided via fuses on the front connector.

Owing to its layout as a "short" card in the European format, the module can be integrated into the front area of the R&S®CompactTSVP. To allow standardized distribution of digital control ports, the R&S®TS-PTRF signal port and transmission module is available. Directly off-the-shelf RF relays or up to eight R&S®TS-PXM1 switching extension modules can be connected to this module. Arriving from the front, DUT signals can also be fed through to the R&S®TS-PIO3B module either directly or via a test fixture.

When installed in slots A1 and A2, three of the digital I/O ports and one SPI interface are available on the rear panel in conjunction with the R&S®TS-PXB2 backplane extension module. When installed in slots 3 to 14, three digital ports of the R&S®TS-PIO3B module are provided on the rear panel via an R&S®TS-PRIO4 rear I/O transmission module.



Tried-and-tested features of the R&S®TS-PIO3B module

- ▮ Eight quasi-bidirectional digital I/O ports with 8 bits each, i.e. 64 digital I/O signals are available
- ▮ Cost-efficient digital I/O module with large number of channels
- ▮ Outputs with MOSFET driver transistors in open drain
- ▮ Circuitry designed for output currents up to 200 mA for robust and reliable relay control
- ▮ All digital I/O ports available on the front panel; three of them also led out to backplane
- ▮ Additionally, eight TTL I/O channels available, i.e. one TTL port for control tasks; if the R&S®TS-PTRF module is used, this port is already reserved internally
- ▮ Eight simple analog inputs on the front panel, signal range: 0 V to 5 V, resolution: 10 bit
- ▮ External SPI interface
- ▮ Provision of +5 V/2 A and +12 V/2 A, fuse-protected on the front connector (X10)
- ▮ Soft front panel for easy interactive manual operation for test purposes
- ▮ DLL driver software and LabWindows/CVI instrument driver available
- ▮ Routing of DUT signals via front-panel R&S®TS-PTRF module
- ▮ Routing of three digital I/O ports and the CAN bus interface to the backplane in the area of slots A1, A2 when using the R&S®TS-PXB2 backplane extension module
- ▮ Routing of three digital I/O ports to the backplane in the area of slots 3 to 14 when using the R&S®TS-PRIO4 option

Block diagram of the R&S®TS-PIO3B

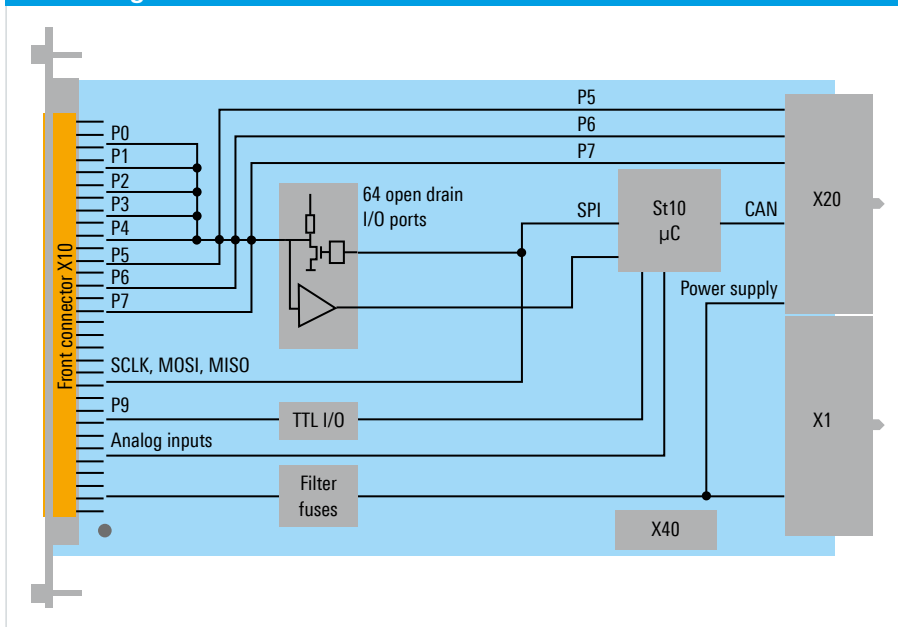

Easy deployment by sophisticated software

Comprehensive software support for all functions of the R&S®TS-PIO3B module

The R&S®TS-PIO3B module is supplied with an IVI-C-compliant LabWindows/CVI driver, which offers function panels and online help as a common feature. Alternatively, all switching functions can be called via the generic test software library (GTSL) switch manager.

Manual operation to evaluate test scenarios and to verify DUT adaptation is provided by a sophisticated soft front panel offering access to the module's full scope of functionalities.

The R&S®TS-PIO3B features are completely described in the GTSL software framework and are delivered to the user as a DLL file to support their use in various programming environments.

Security through selftest and diagnostics

The built-in selftest capability of the module provides fast diagnostics to verify base interface functionalities. The scanning tool derives the VISA address by a mouseclick and enables the user to verify proper interface operation at a glance.

Soft front panel of the R&S®TS-PIO3B module for interactive operation.

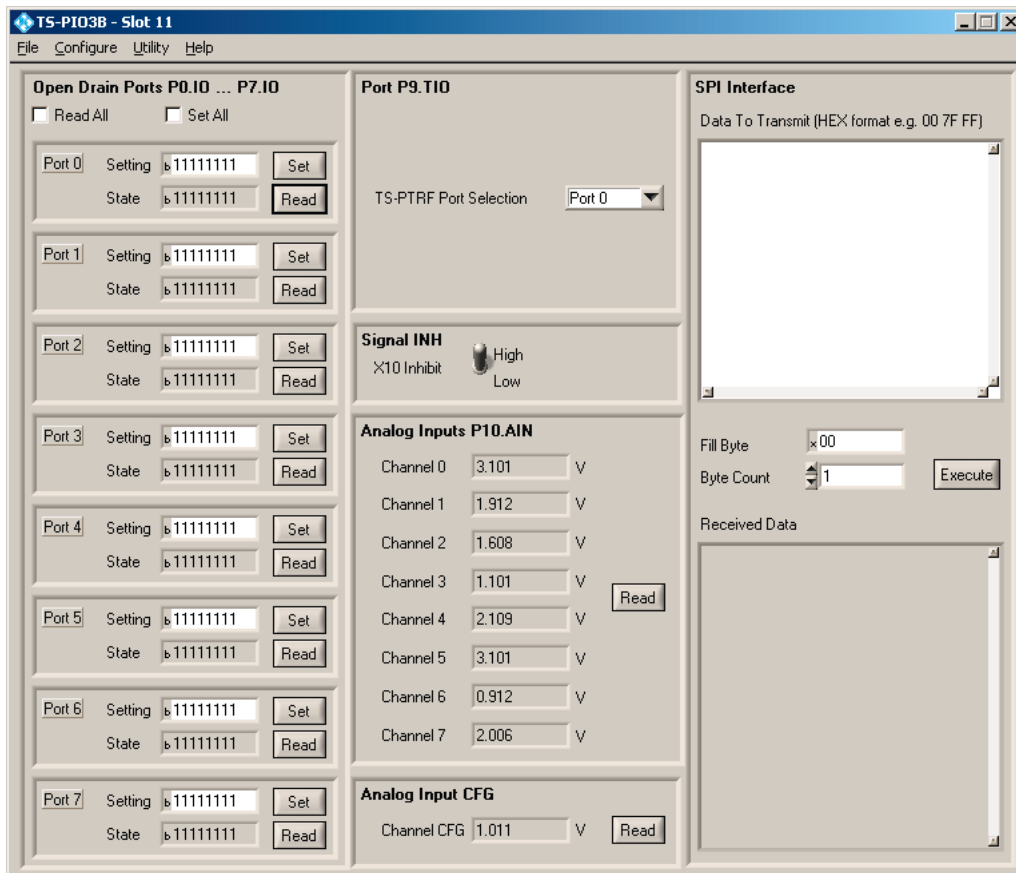
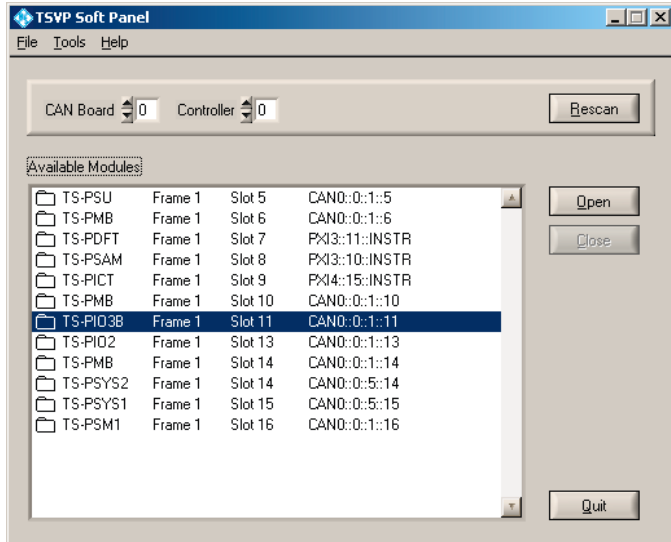

R&S®TS-PTRF Signal Port and Transmission Module

The distribution of the digital control signals to various relays and DUT pins often requires complex cabling. A uniform and standardized means of distributing digital signals considerably simplifies signal routing; a front-panel port distribution module even allows the combined control of internal relays and external auxiliary circuits with a single accessory module.

Flexible distribution of digital port signals of the R&S®TS-PIO3B module

The R&S®TS-PTRF is an accessory module for routing digital control lines of the R&S®TS-PIO3B digital I/O module to the front panel of the R&S®CompactTSVP or R&S®PowerTSVP. In both instruments, the module is connected as a switching and distribution module in front of an R&S®TS-PIO3B or an R&S®TS-PTR signal transmission module and offers a variety of ways to route signals.

The module connects the eight open drain I/O ports of the R&S®TS-PIO3B to connectors on which relay modules can be controlled. Plus, the module generates SPI chip select signals for external SPI components or ones located on the relay modules. Simple pin connections on the module thus make it possible to provide digital control ports for operating R&S®TS-PXM1 switching extension modules, which makes expansions in DUT control an easy matter.

The R&S®TS-PIO3B digital I/O module is designed as a universal coil driver. In conjunction with the R&S®TS-PTRF option, any number of external relays or built-in switching relays – particularly relays for RF signal routing – can be connected in a standardized manner. In this case, the R&S®TS-PTRF module is used as the port distributor.

- Uniform and cost-efficient connection of instrument-internal and externally operated relays, and especially of RF relays
- Control and routing of DUT signals with the R&S®TS-PIO3B digital I/O module and the R&S®TS-PTRF signal port and transmission module
- Connection of up to eight R&S®TS-PXM1 switching extension modules
- Breakout and routing of signals cabled in the instrument to DUTs via the passive R&S®TS-PTR signal transmission module
- Wiring of the eight open drain I/O ports of the R&S®TS-PIO3B to eight pin connectors
- Configurable wiring of the eight open drain I/O ports of the R&S®TS-PIO3B to the front panel via jumpers
- Generation and optional wiring of eight SPI chip select (CS) signals to the front panel via jumpers
- Generation of a local 5 V supply to the front panel and the connected R&S®TS-PXM1 switching extension modules
- Interface for connecting to the analog bus of the R&S®TSVP instruments

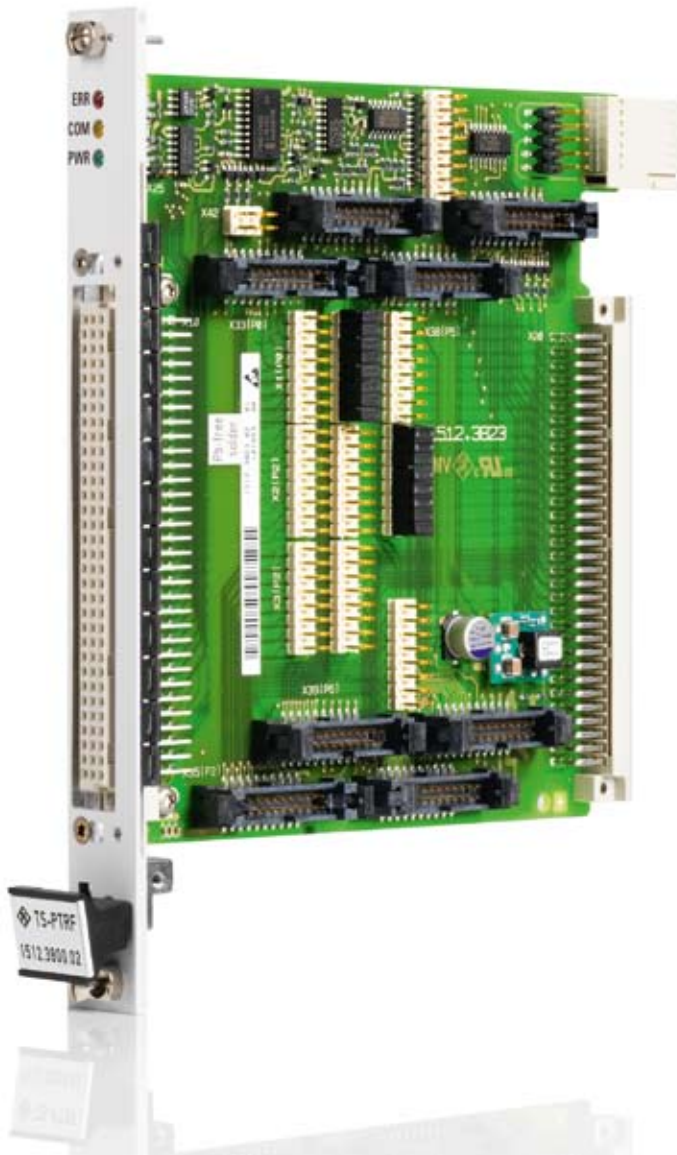

Attach various accessory modules and build switching and digital I/O extensions at lowest cost

The application example shows the simple connection of ports to an R&S®TS-PXM1 switching extension module and a project-specific configured RF switching module.

Additional functionalities for linking to DUTs are made possible owing to the following features:

Local +5 V/+12 V supply voltages

The R&S®TS-PTRF module receives a +12 V supply voltage from the R&S®TS-PIO3B digital I/O module or from the passive R&S®TS-PTR signal transmission module. This voltage is converted to +5 V directly on the front module and is made available externally and at all ports from P0 to P7 on connectors X33 to X40. The likewise available +12 V supply voltage is protected on the R&S®TS-PIO3B or on the R&S®TS-PTR via safety fuses. The +5 V supply voltage is not fuse-protected, but it is short-circuit-proof. The converter can deliver an output current of max. 2 A at 5 V.

Analog bus access

The R&S®TS-PTRF provides a connector to the analog bus. When the module is used in slots 3 to 14 in the R&S®CompactTSVP or in slots 1 to 14 in the R&S®PowerTSVP, contact is established between connector X30 and the analog bus. The eight lines of the analog bus are routed to connector X32.

Distribution of digital I/O ports

For each open drain I/O port (0 to 7) of an attached R&S®TS-PIO3B, the R&S®TS-PTRF provides contact to one plug-in connector from X33 to X40. Furthermore, each open drain I/O port of the R&S®TS-PIO3B can optionally be led out to the front panel via jumpers.

Additional simple analog measurement channels

The eight analog inputs of the R&S®TS-PIO3B module can optionally be led out to the front panel via jumpers. Furthermore, one analog line each is routed to plug-in connectors X33 to X40.

Application of the R&S®TS-PTRF module

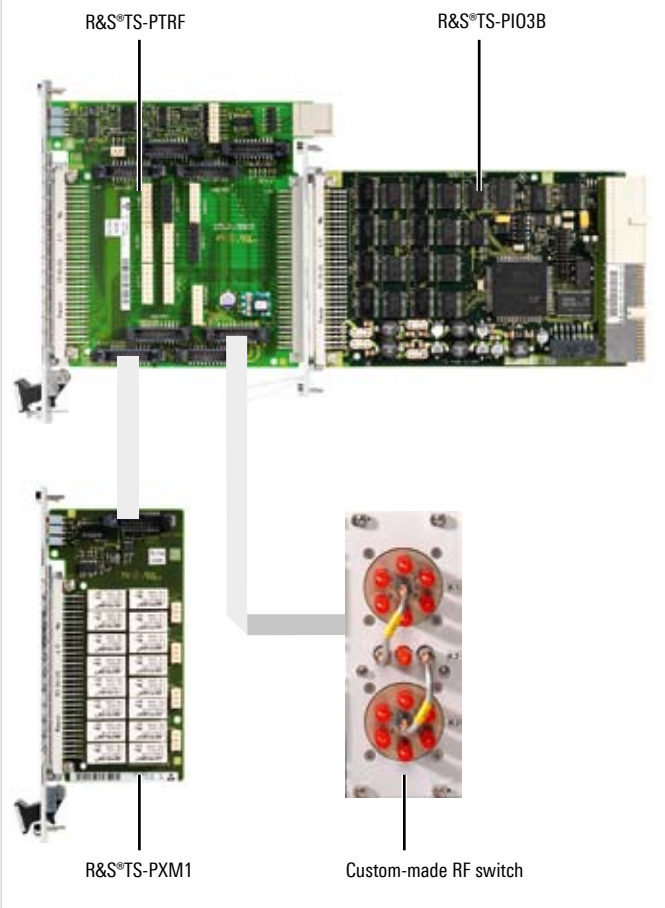

Block diagram of the R&S®TS-PTRF

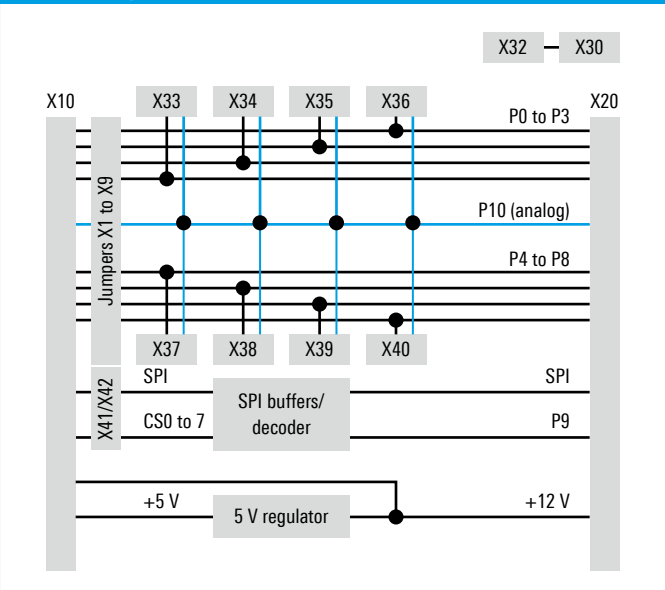

R&S®TS-PXM1 Switching Extension Module

Often, simple switches or multiplexers are needed for temporarily establishing or breaking DUT contacts that must be provided cost-efficiently in the modular instrument.

General-purpose switching for flexible extensions of the R&S®TS-PIO3B digital I/O module

The R&S®TS-PXM1 is a switching extension module with a total of 32 switches, arranged in eight groups with four switches each. It can always be used when additional simple switches or multiplexers are needed for the programmable making or breaking of DUT contacts. Control is carried out via an R&S®TS-PIO3B digital I/O module that must be equipped with a front-panel R&S®TS-PTRF signal port and transmission module. The simple switching module can be connected to any of the port distribution connectors of the R&S®TS-PTRF which provides a total of eight control ports.

All relays are change-over switches; the signal lines are available on the front connector and can switch DUT signals or low-impedance supply voltages up to 2 A. The switches are likewise ideal for the simple routing of audio signals. A storage chip on the R&S®TS-PXM1 switching extension module enables the controlling digital I/O module to identify the module by means of software. The LED diagnostics that are standard for the R&S®TSVP modules are available on this accessory module for seamless integration.

- Breakout and routing of internal signals from PXI modules, e.g. boundary scan lines
- Discrete wiring of DUTs with auxiliary voltages in the functional test
- Connection of load resistances to DUT outputs
- Simple control via one R&S®TS-PIO3B control port each for up to eight R&S®TS-PXM1 modules
- For use on slots A1 to A4, which in the past were ordinarily not used for DUT connections, and in front of controller slots 1 and 2; if needed, PXI slots can be kept free for additional measurement modules



R&S®TS-PXB2 Backplane Extension Module

The R&S®TS-PIO3B digital I/O module for standard functions such as the routing of RF relays or relays for power supply can be reliably operated via the system's internal CAN bus also in the area of slots A1 and A2. A backplane extension module is provided for this purpose. This leaves PXI slots free, preferably for the use of high-performance measurement modules.

Two slots for accessory modules

Flexible expansion of the R&S®CompactTSVP and R&S®PowerTSVP with two additional CAN bus slots

The R&S®TS-PXB2 is a backplane extension module for slots A1 and A2. These two slots to the left of the standard plug-in power supply were previously reserved for an additional power supply.

The R&S®TS-PXB2 option now makes two additional CAN bus slots available. The digital I/O standard functionality and the coil driver can thus be implemented in a uniform manner and cost-effectively with dedicated R&S®TS-PIO3B digital I/O modules. As a result, PXI slots can be kept free to preferably equip them with measurement modules.

The cabling kit for the backplane extension option includes a breakout of the system CAN bus on the rear I/O slot 4 for controlling remote modules directly in the test fixture.

Furthermore, the R&S®TS-PXB2 option makes it possible to route 24 signals to the instrument's backplane, e.g. from the digital I/O ports 5, 6 and 7 of the R&S®TS-PIO3B option.

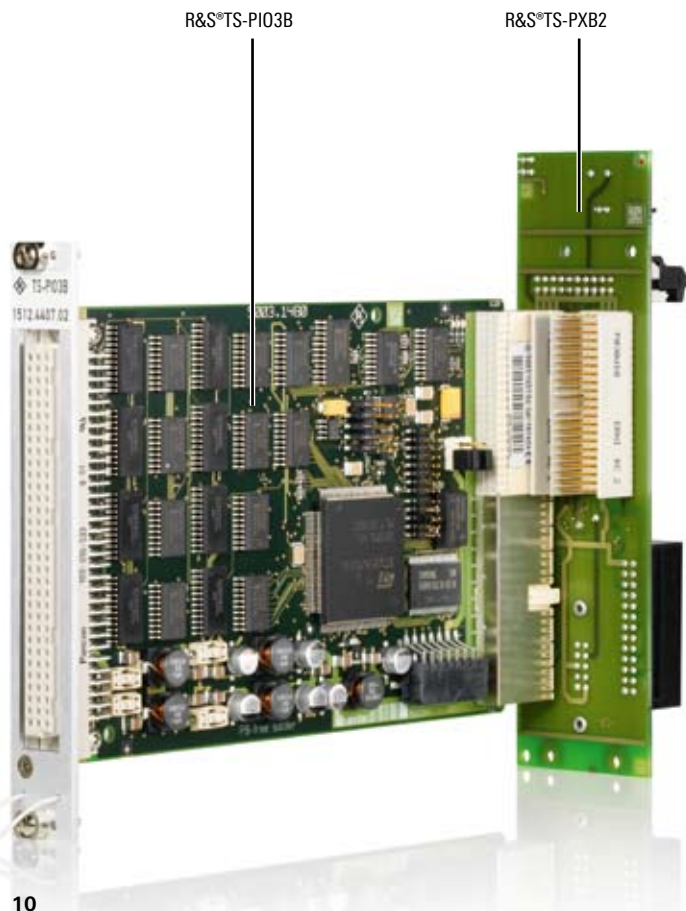

Note

The R&S®TS-PXB2 option cannot be used together with the R&S®TS-PCPA power supply extension.

The following applications are additionally made possible with the R&S®TS-PXB2 module:

- Expansion by two CAN bus slots without linkup to the analog bus
- Breakout of the CAN bus to the rear panel
- Breakout for the 24 digital I/O channels each of slots A1 and A2 on the rear panel
- Use in the R&S®CompactTSVP and R&S®PowerTSVP

Chassis extensions

Add two CAN bus slots to R&S®TSVP instruments

The R&S®TS-PXB2 option expands the R&S®CompactTSVP test system versatile platform by two CAN-bus-controlled slots at A1 and A2. It can be integrated ex works only. The two slots are intended for the deployment of the R&S®TS-PIO3B or R&S®TS-PTR modules.

In addition, the internal CAN bus for switching control is available via a standard CAN connector at rear I/O slot A4.

Connectivity of the R&S®TS-PXB2 backplane extension module on the rear panel

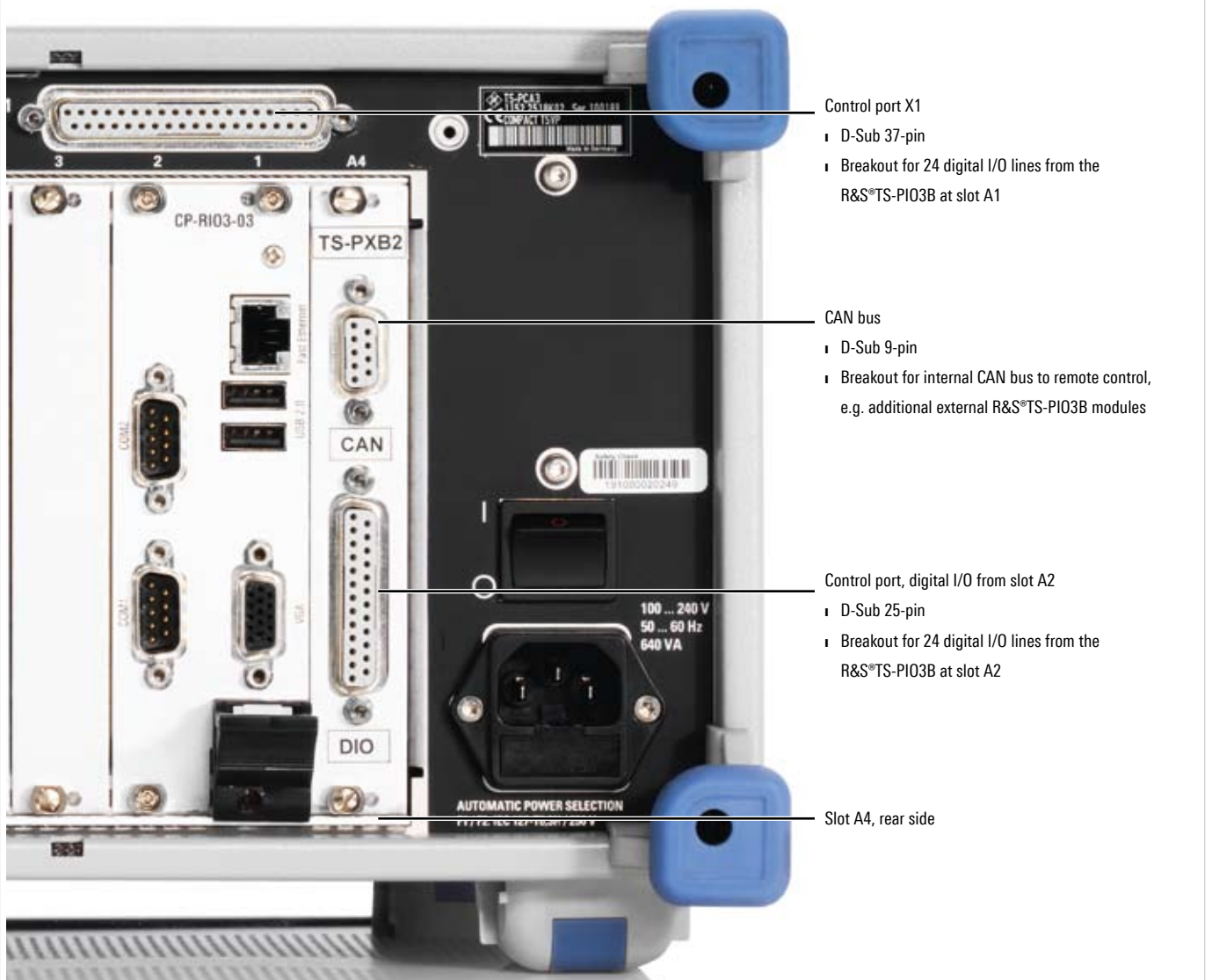

R&S®TS-PRIO4

Rear I/O

Transmission

Module

In the case of the front-panel industrial mass interconnection of DUTs via test fixtures, the front of a tester is occupied by an adaptation frame. Therefore, an effort is being made to find a way to route signals of external T&M equipment to the DUT via the rear panel of the test instrument.

Off-the-shelf routing of port signals of the R&S®TS-PIO3B digital I/O module or of DUT signals of the R&S®TS-PTR signal transmission module

The R&S®TS-PRIO4 is an accessory module to route digital control lines of the R&S®TS-PIO3B digital I/O module to the rear panel of the R&S®CompactTSVP or R&S®PowerTSVP. In both instruments, the module is inserted as a switching module on the rear panel of an R&S®TS-PIO3B or of an R&S®TS-PTR signal transmission module. This enables users to route external measuring equipment to the front-panel test fixture via the rear panel in a simple and standardized manner.

The module connects three open drain I/O ports of the R&S®TS-PIO3B to a male connector on the rear panel of the R&S®TSVP modular equipment.

Using the R&S®TS-PIO3B digital I/O module, any number of relays – and particularly relays for RF signal routing – can be controlled via the rear panel.

- Breakout of three open drain ports of the R&S®TS-PIO3B to the rear panel via jumpers
- Breakout of internal signals to DUTs on the rear panel via the passive R&S®TS-PTR signal transmission module
- Transmission of signals at the front panel to the rear panel (and vice versa) via the R&S®TS-PTR and R&S®TS-PTRF modules



R&S®TS-PTR Signal Transmission Module

Simple routing of DUT signals to the rear panel using the R&S®CompactTSVP and the R&S®PowerTSVP

The R&S®TS-PTR is an accessory module for transmitting DUT signals through the system equipment of the R&S®TSVP family. The module's design as a passive switching board protects the signal-routing lines that are connected via the front-panel plug-in connector of an R&S®TS-PTRF module. When it comes to conducting and connecting a large number of signal paths through the instrument and then to the DUT, this standardized signal transmission module is fundamentally more cost-efficient than a project-specific cabling solution.

The R&S®TS-PTR module enables these signals to reach the R&S®TS-PXB2 backplane extension module with connectors on the rear panel.

The module is mechanically compatible with the R&S®TS-PIO3B and is used as a switching and distribution module in place of an R&S®TS-PIO3B module. In order to route DUT signals in slots 3 to 14, which are used for T&M purposes, by means of an R&S®CompactTSVP or an R&S®PowerTSVP, an additional rear I/O module of the R&S®TS-PRIO4 is used.

- Routing of DUT signals via the front-panel R&S®TS-PTRF module and the R&S®TS-PRIO4 rear I/O transmission module in slots 3 to 14
- Routing of DUT signals in the area of slots A1 and A2 to the R&S®TS-PTR signal transmission module via the front-panel R&S®TS-PTRF module. In place of an R&S®TS-PIO3B module, this approach creates an alternative cabling solution for routing DUT signals to the backplane. To make this possible, the R&S®TS-PXB2 backplane extension module likewise includes the backplane connectors
- Wiring of 3 × 8 lines through a chassis, i.e. 24 passive lines between X20 and X10
- Provision of +5 V and +12 V, fuse-protected on the front connector (X10)

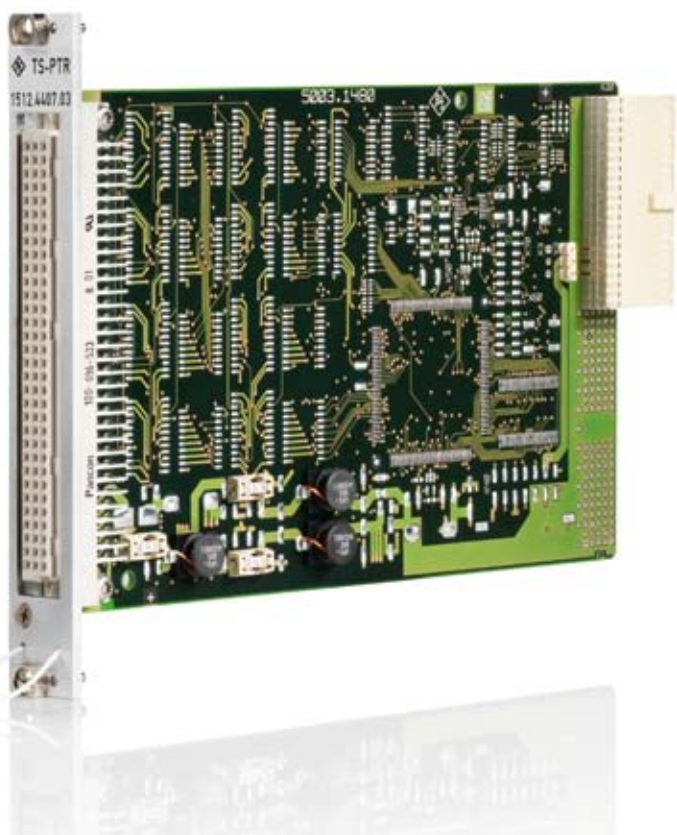

Specifications

R&S®TS-PIO3B		
Application in the R&S®TSVP platform	R&S®CompactTSVP or R&S®PowerTSVP	1 slot on front
Interface		
Control bus		CAN 2.0b (1 Mbit/s)
DUT connector (front)		DIN41612, 96 pins
Input/output (I/O) channels (digital)		
Digital I/O and coil driver with power output		
Number of channels		64 × open drain in 8 pin groups can be fed back (ports P0 to P7), with 24 of them (ports P5 to P7) available on rear I/O
Px.IOy voltage		0 V to 35 V
Px.IOy current sink		max. 200 mA per bit
Px current sink		max. 1 A per port
P0 to P7 current sink sum		max. 2 A
Px.IOy FET "ON" resistance		typ. 1 Ω
Px.IOy input low		< 0.8 V
Px.IOy input high		> 2.0 V
Digital I/O with TTL output		
Number of channels		8 × input/output, TTL
Level range		0 V to 5 V
Max. output current		±15 mA
Input channels (analog)		
Number of channels		8 × input
Level range		0 V to 5 V
Resolution		10 bit
Accuracy		±(100 mV + 5%)
SPI interface		
SPI	SCLK, MOSI	5 V TTL output with 300 Ω series resistance
	MISO	5 V TTL input

Digital I/O and coil driver with power output

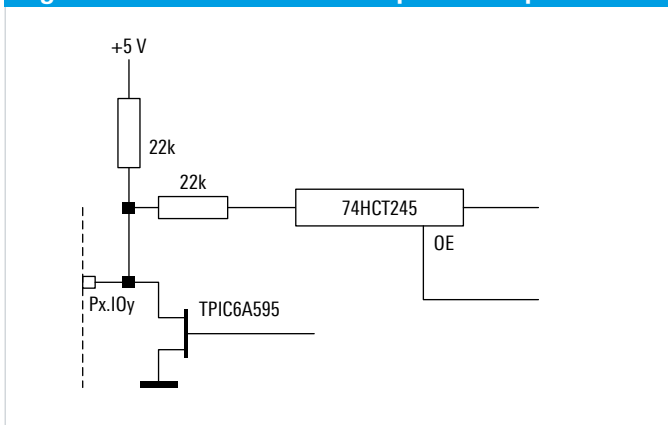

Digital I/O with TTL output

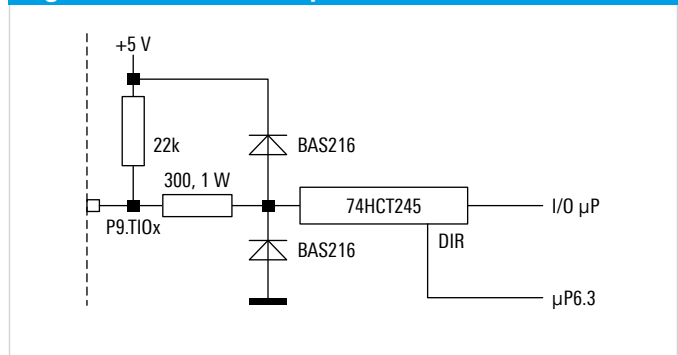

R&S®TS-PTRF		
Application in the R&S®TSVP platform	R&S®CompactTSVP or R&S®PowerTSVP	1 slot in front of R&S®TS-PIO3B or R&S®TS-PTR
DUT connector (front)		DIN41612, 96 pins
Port connector		multipoint connector 20-pin, 2 mm, 2-row
Control ports		
Number of control ports (internal)		8 (8 bits each)
Number of SPI chip select		8 (active low)
Configurable routing of R&S®TS-PIO3B signals to the fixture interface		
Number of open drain ports		8 (8 bits each)
Number of SPI chip select		8 (active low)
SPI interface		1
Analog port		8 lines
R&S®TS-PXM1		
Application in the R&S®TSVP platform	R&S®CompactTSVP or R&S®PowerTSVP	1 slot on fixture interface, no slots on backplane
DUT connector (front)		DIN41612, 96 pins
Multipoint connector		8-pin, 2.54 mm; 2 relays type Zettler AZ832
Switching voltage		125 V V _p /30 V DC
Switching current		2A/30 V DC resistive or 2A/125 V V _p (AC) resistive
Switching power		60 W/250 VA
Relay control		8-bit, low active
Relay organization		8 × 4PDT
R&S®TS-PXB2		
Application in the R&S®TSVP platform	R&S®CompactTSVP or R&S®PowerTSVP	
Bus system		CAN 2.0b, 1 Mbit
Number of additional slots		2, position: A1 and A2
Feedthrough to backplane		24 lines per slot, position X1; D-Sub 37-pin, female, and position slot A4/DIO; D-Sub 25-pin, female, and position CAN on A4/CAN; D-Sub 9-pin, female
R&S®TS-PRIO4		
Application in the R&S®TSVP platform	R&S®CompactTSVP or R&S®PowerTSVP	1 slot in rear I/O area
DUT connector		D-Sub 37-pin, female
Feedthrough to backplane		24 lines
R&S®TS-PTR		
Application in the R&S®TSVP platform	R&S®CompactTSVP or R&S®PowerTSVP	1 slot on front
DUT connector (front)		DIN41612, 96 pins
Feedthrough from backplane to DUT connector		24 lines

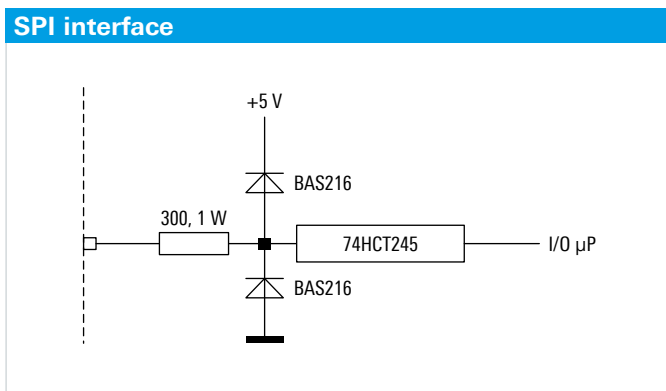

General data		
Power consumption		
R&S°TS-PIO3B	+5 V	max. 200 mA (excludes P9 output power)
	+12 V	0 A
R&S°TS-PTRF	+5 V	max. 50 mA
	+12 V	max. 24 W
R&S°TS-PTR		0 (passive module)
R&S°TS-PXM1	+5 V	20 mA + 75 mA per control bit set to "0"
	+12 V	10 mA
Output power		
R&S°TS-PIO3B	+5 V	max. 2 A
	+12 V	max. 2 A
R&S°TS-PTRF	+5 V	max. 2 A
	+12 V	max. 2 A
	total	max. 24 W
R&S°TS-PXB2	+5 V	2 A
	+12 V	2 A
R&S°TS-PTR	+5 V	max. 2 A
	+12 V	max. 2 A
Electromagnetic compatibility		in line with EMC directive 2004/108/EC, EMC standard EN61326, EN55011
Safety		in line with CE, EN61010 part 1
Temperature range		operating temperature range +5°C to +40°C, in line with EN60068-2-2
		permissible temperature range 0°C to +50°C, in line with EN60068-2-2
		storage temperature range -40°C to +70°C, in line with EN60068-2-2
Humidity		+40°C, 95% relative humidity, in line with EN60068-2-78
Mechanical resistance		vibration, sinusoidal 5 Hz to 55 Hz: max. 1.8 g at 55 Hz, 55 Hz to 150 Hz: 0.5 g constant, in line with EN60068
		vibration, random 10 Hz to 300 Hz, 1.2 g RMS, in line with EN60068
		shock SRS, 40 g, MIL-STD-810F method 516.5, procedure I
Dimensions		W × H × D
	R&S°TS-PIO3B	175 mm × 100 mm × 20 mm (6.89 in × 3.94 in × 0.79 in)
	R&S°TS-PTRF	140 mm × 174 mm × 20 mm (5.51 in × 6.85 in × 0.79 in)
	R&S°TS-PXM1	88 mm × 17 mm × 20 mm (3.46 in × 0.67 in × 0.79 in)
	R&S°TS-PXB2	40.5 mm × 150 mm × 40 mm (1.59 in × 5.91 in × 1.57 in)
	R&S°TS-PRIO4	130 mm × 128 mm × 20 mm (5.12 in × 5.04 in × 0.79 in)
	R&S°TS-PTR	180 mm × 128 mm × 20 mm (7.09 in × 5.04 in × 0.79 in)
Weight		R&S°TS-PIO3B 150 g (0.33 lb)
		R&S°TS-PTRF 160 g (0.35 lb)
		R&S°TS-PXM1 163 g (0.36 lb)
		R&S°TS-PXB2 160 g (0.35 lb)
		R&S°TS-PRIO4 115 g (0.25 lb)
		R&S°TS-PTR 150 g (0.33 lb)

Ordering information

Designation	Type	Order No.
Test & measurement chassis		
R&S®CompactTSVP, Compact PCI/PXI-based platform	R&S®TS-PCA3	1152.2518.02
R&S®PowerTSVP, CAN-based switching platform	R&S®TS-PWA3	1157.8043.02
Digital I/O modules and accessories		
Digital I/O Module and Coil Driver, 64-channel open drain for R&S®TSVP	R&S®TS-PIO3B	1512.4407.02
Signal Port and Transmission Module for R&S®TS-PIO3B or R&S®TS-PTR	R&S®TS-PTRF	1512.3800.02
Switching Extension Module, 8 × 4PDT	R&S®TS-PXM1	1512.4007.02
Backplane Extension Module, CAN bus, 2 slots	R&S®TS-PXB2	1512.3600.02
Rear I/O Transmission Module for R&S®TS-PIO3B, R&S®TS-PTR	R&S®TS-PRIO4	1510.8005.02
Signal Transmission Module for R&S®TS-PRIO4, R&S®TS-PTRF	R&S®TS-PTR	1512.4407.03
Spare parts		
Microfuse SMD 2A-T for R&S®TS-PIO3B or R&S®TS-PTR		1090.4094.00

Your local Rohde & Schwarz expert will help you determine the optimum solution for your requirements and will be glad to provide you with a customized quotation.

To find your nearest Rohde & Schwarz representative, visit

www.sales.rohde-schwarz.com

Service you can rely on

- ▮ Worldwide
- ▮ Local and personalized
- ▮ Customized and flexible
- ▮ Uncompromising quality
- ▮ Long-term dependability

About Rohde & Schwarz

Rohde & Schwarz is an independent group of companies specializing in electronics. It is a leading supplier of solutions in the fields of test and measurement, broadcasting, radiomonitoring and radiolocation, as well as secure communications. Established 75 years ago, Rohde & Schwarz has a global presence and a dedicated service network in over 70 countries. Company headquarters are in Munich, Germany.

Environmental commitment

- ▮ Energy-efficient products
- ▮ Continuous improvement in environmental sustainability
- ▮ ISO 14001-certified environmental management system

Certified Quality System
ISO 9001

Rohde & Schwarz GmbH & Co. KG

www.rohde-schwarz.com

Regional contact

- ▮ Europe, Africa, Middle East
+49 89 4129 137 74
customersupport@rohde-schwarz.com
- ▮ North America
1 888 TEST RSA (1 888 837 87 72)
customer.support@rsa.rohde-schwarz.com
- ▮ Latin America
+1 410 910 79 88
customersupport.la@rohde-schwarz.com
- ▮ Asia/Pacific
+65 65 13 04 88
customersupport.asia@rohde-schwarz.com