

R&S®UPV

Audio Analyzer

Compact instrument for all audio measurements



R&S®UPV

Audio Analyzer

At a glance

Although audio signals are mainly processed digitally nowadays, analog technology will remain a viable alternative that is continuously being enhanced. Therefore, both analog and digital measurements must be performed. The R&S®UPV audio analyzer is designed precisely for this purpose.

The R&S®UPV enables users to perform virtually all measurements that are necessary in the audio world: frequency response measurement, total harmonic distortion (THD) displays, spectral displays, analysis of digital interfaces, and much more. The generator is just as versatile. It can be used to create any conceivable signal from sinewave and noise signals up to multi-sinewave signals.

The R&S®UPV is an all-in-one instrument with an integrated control PC, making it easy to transport. Since the instrument comes factory-ready, it merely needs to be unpacked and switched on before being put into operation. Peripherals are therefore not required. Optional modules and software expansions that can be integrated into the instrument open up a broad scope of further applications.

The R&S®UPV features an intuitive user interface (Windows XP operating system). The large screen plays a key role, not only for displaying measurement results. All settings are made in panels that contain all interrelated functions and settings. Since the operating philosophy is easy to understand and since analog and digital measurements are performed in a similar manner, users can quickly master instrument operation.

The instrument features scalable graphical windows that can be moved around on the screen as needed, providing all measurement results at a glance. Results can be displayed in realtime for one or both channels and can optionally be expanded to a maximum of 16 channels. Multiple measurement functions/graphics are available simultaneously. For example, analyses in the frequency and time domains can be displayed at the same time. With graphics, results can be read off using vertical and horizontal cursors, and limit lines or stored measurement results can be superimposed on them or compared with them.

Key facts

- Suitable for all interfaces (analog, digital and combined)
- Simultaneous display of multiple measurement functions
- Sampling rate up to 400 kHz
- User-programmable filters for analyzer and generator
- Compact instrument with integrated PC
- Slots for future options

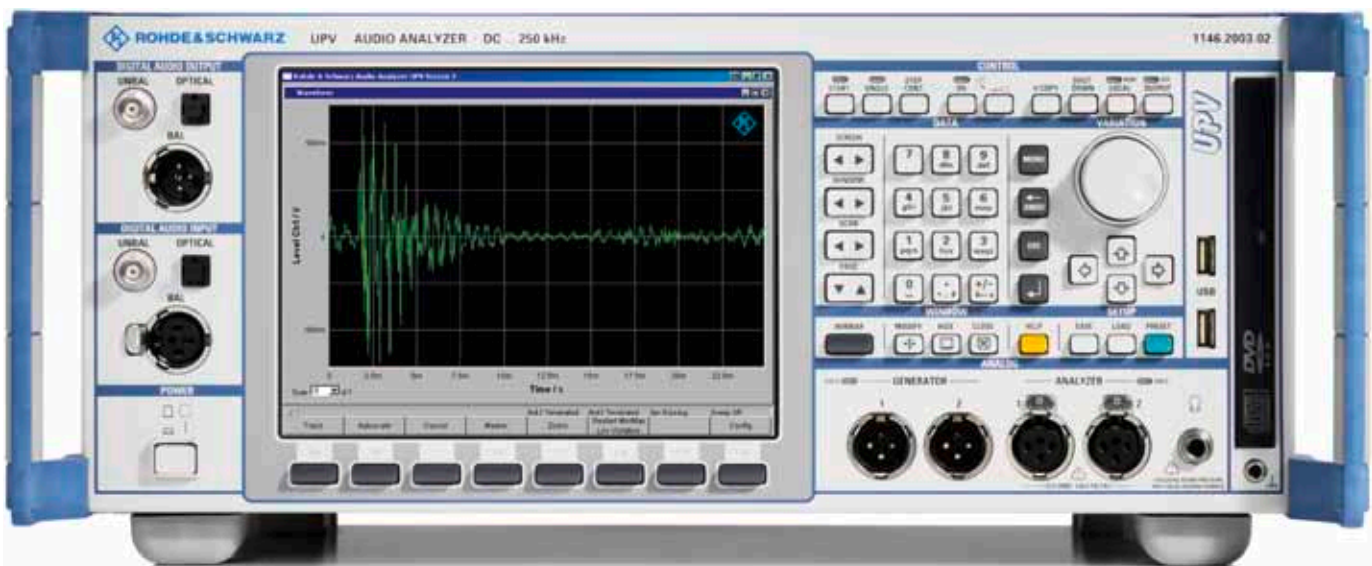

R&S®UPV

Audio Analyzer

Benefits and key features

All test signals and measurement functions in a single box

- Generation of a wide variety of analog and – by using the R&S®UPV-B2/-B41/-B42 options – digital test signals
- Extensive measurement capabilities, on analog and also – when the R&S®UPV-B2/-B41/-B42 options are installed – digital interfaces
- Efficient as well as multichannel FFT analysis with a resolution down to the mHz range
- User-programmable filters adaptable to the measurement task at hand in a matter of seconds
- Everything included, no peripherals required

▷ [page 4](#)

Largest variety of interfaces offered in a single instrument

- Analog generator outputs as standard
- Dual-channel analyzer with analog inputs as standard
- Expansion to 8 or 16 measurement channels (R&S®UPV-B48 option)
- Digital audio interfaces (R&S®UPV-B2 option)
- Digital protocol analysis and generation (R&S®UPV-K21 option)
- Jitter and interface test (R&S®UPV-K22 option)
- Test of audio ICs with I²S interface (R&S®UPV-B41 option)
- Virtually any audio circuit adaptable using the universal serial interface (R&S®UPV-B42 option)
- PDM bitstream analysis (R&S®UPV-K421 option)
- For both the generator and analyzer, all interfaces can be adjusted independently of one another, and they may be used together in any combination

▷ [page 8](#)

Convenient operation throughout

- Owing to the intuitive user interface, operation can be learned in next to no time
- All measurement results at a glance
- Effective online help functions

▷ [page 12](#)

Powerful and fast

- High measurement speed throughout the system
- Especially suitable for use in production
- R&S®UPV-K1 universal sequence controller for entire measurement sequences

▷ [page 14](#)

Options for further applications

- R&S®UPV-B1 low distortion generator for extremely pure analog sinewave signals and for expanding the frequency range
- Second analog generator (R&S®UPV-B3) for generating different sinewave signals on the two analog output channels
- Simultaneous pickup of measurement values for up to 16 analog channels with the R&S®UPV-B48 option (eight channels each)
- 192 kHz R&S®UPV-B2 digital audio I/O with digital audio interfaces in line with AES/EBU and in consumer format
- Universal digital interfaces (R&S®UPV-B42) or in I²S format (R&S®UPV-B41) for connecting digital audio circuits
- PDM bitstream analysis (R&S®UPV-K421) as an add-on to the R&S®UPV-B42 option
- Expanded analysis functions with the R&S®UPV-K6 option
- PESQ® measurement¹⁾ (R&S®UPV-K61 option) for analyzing speech signals in line with psycho-acoustic methods
- PEAQ® measurement¹⁾ (R&S®UPV-K62 option) for analyzing broadband audio signals in line with psycho-acoustic methods
- POLQA® measurement¹⁾ (R&S®UPV-K63 option) for analyzing broadband speech quality in line with psycho-acoustic methods
- Standard-compliant measurement of hearing aids using the R&S®UPV-K7 and R&S®UPV-K71 options
- R&S®UPV-K9/-K91/-K92 option package for acoustic measurements on mobile phones
- R&S®UPV-K4 remote control option for remote control of the R&S®UPV audio analyzer
- R&S®UPV-K1 universal sequence controller for creating and executing measurement sequences
- Change of the source impedance from 200 Ω to 150 Ω (R&S®UPV-U1 option)
- BNC monitoring outputs (R&S®UPV-U2 option)
- XLR/BNC adapter set (R&S®UPV-Z1MF option)
- R&S®UPV audio switcher for switching up to 128 channels to the inputs and outputs

▷ [page 16](#)

¹⁾ PESQ®, PEAQ® and POLQA® are registered trademarks of OPTICOM Dipl.-Ing. M. Keyhl GmbH, Germany.

All test signals and measurement functions in a single box

The generator of the R&S®UPV audio analyzer generates a variety of signals, here a 32-tone signal: Frequency, amplitude and phase can be adjusted.

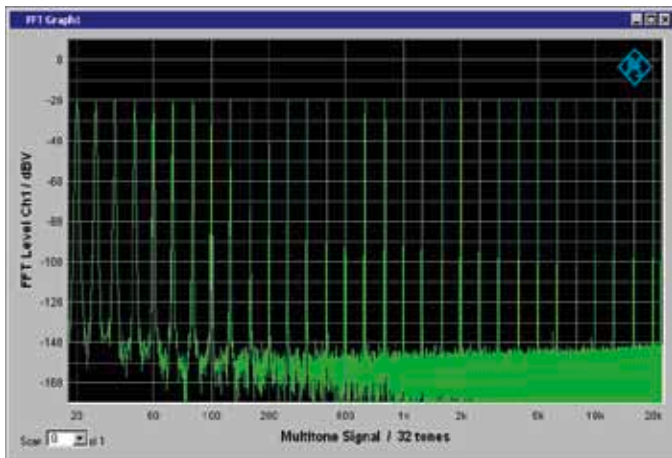

The waveform function shows the time characteristic of the measured signal (in this case, a sine burst).

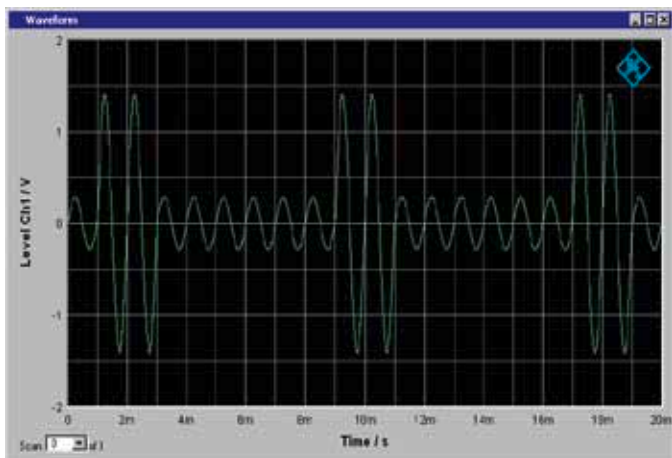

The generators of the R&S®UPV can generate a wide variety of analog and digital test signals

Sinewave signal...

...for level and THD measurements

Dual-channel sinewave signals

Different signals are always possible on both digital output channels; for the analog interfaces, the R&S®UPV-B3 option is required

Two-tone signal...

...for modulation distortion analysis; various amplitude ratios can be selected; continuous frequency adjustment is possible

Difference-frequency distortion...

...for intermodulation measurements with continuous adjustment of both frequencies

DIM test signal

Squarewave signal with superimposed sinewave (R&S®UPV-B3 required in analog applications)

Multitone signals...

...from up to 7400 frequencies with either identical or user-selectable amplitude and phase; the frequency spacing can be linked to the resolution used for the fast Fourier transform (FFT), which allows the frequency response of a DUT to be determined quickly and precisely in one shot

Sine burst signal and sine² burst...

...with adjustable interval time and "on" time as well as user-programmable low level, e.g. for testing automatic gain control devices

Noise...

...with various amplitude distribution functions, e.g. for acoustic measurements

Arbitrary signals

Any voltage characteristic from up to 256k points can be generated

With the play function...

...any test signals can be output from the hard disk, e.g. speech or music signals provided as a WAV file

AM and FM...

...for sinewave signals

DC voltage...

...also with sweep function

Squarewave signal

(R&S®UPV-B3 option required in analog applications)

A user-programmable filter and/or equalizer with user-selectable nominal frequency response can be inserted with most signals in order to compensate for the frequency response of the test setup, for example.

An offset can also be added to the signals; plus, a dither with an adjustable level and different amplitude distribution can be added to the digital audio signals.

The R&S®UPV can perform a broad scope of measurements on both analog and – optionally – digital interfaces

Level or S/N measurement...

...with RMS, peak or quasi-peak weighting; integration times that are automatically adapted to the input signal produce high measurement speeds

Selective level measurement

The center frequency of the bandpass can be swept or coupled to the generator frequency or to the input signal

SINAD or THD+N measurement

Measurement of the sum of all harmonics, including noise

Measurement of total harmonic distortion (THD)

Analysis of the harmonics, either individual ones, all of them, or any combination of them

Modulation distortion analysis in line with IEC 60268-3

Second- and third-order intermodulations are measured

Intermodulation measurement...

...in line with the difference-frequency distortion method with measurement of the second- or third-order intermodulations

Dynamic intermodulation measurement...

...in line with the DIM standard

DC voltage measurement

Frequency, phase and group delay measurement

Polarity test...

...to check for any polarity reversal of a signal path

Crosstalk measurement

Waveform function...

...for displaying the measurement signal in the time domain; displays of slow time sequences can be compressed, e.g. in order to determine the settling of compressor or AGC circuits

FFT analysis...

...with a wide variety of capabilities (described in detail on page 6)

Record function...

...permits the long-term recording of a signal on the hard disk so that it may be analyzed in detail at a later time

Measurement of time difference...

...between output and input signal; this capability enables users to determine the delays of equalizers, mixing consoles, etc.

R&S®UPV-K6 expanded analysis function

Third-octave analysis and 1/n octave analysis for acoustic measurements; rub & buzz, transfer and coherence functions, as well as impulse response and interchannel delay, expand the range of applications (see page 17)

Psycho-acoustic measurement methods

PESQ, PEAQ and POLQA in line with ITU recommendations are described on page 17

During the THD measurement, all, individual or any combination of harmonics can be measured.

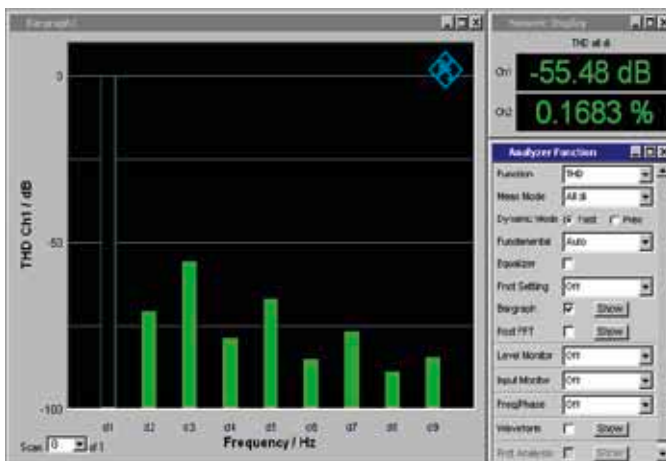

Even less common measurement functions such as the measurement of the dynamic intermodulation (as seen here) can be performed using the R&S®UPV audio analyzer.

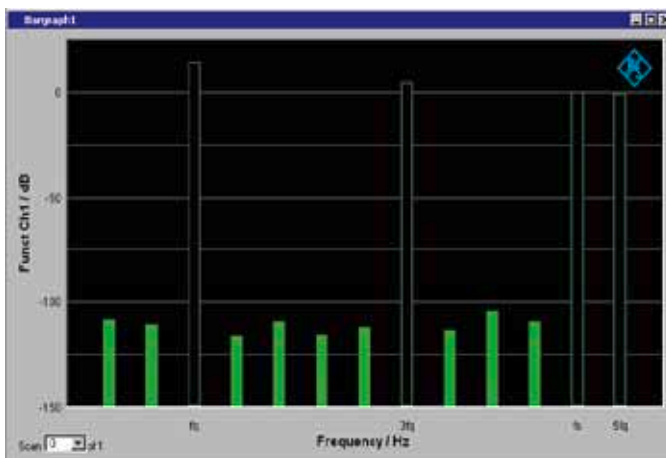

Efficient as well as multichannel FFT analysis with a resolution down to the mHz range

The R&S®UPV offers several FFT capabilities, each of them is designed for two- or multichannel applications and can be applied to the filtered or unfiltered input signal:

FFT

The FFT measurement function is used when high requirements are placed on the dynamic range. Up to 256k points can be selected in binary steps, where the points are evaluated in double precision mode.

Post FFT

The post FFT can be used, for example, in THD and intermodulation measurements to analyze the distortion products in greater detail.

Undersample FFT

A special feature is the undersample FFT (R&S®UPV-K6 option required). Here, digital preprocessing of the measurement signals, which reduces the bandwidth, is used to increase the frequency resolution by a factor of 2 to 1024. This yields a resolution of down to 0.2 mHz. It should be noted that this does not involve a zoomed graphical display, but instead a measurement with true higher resolution.

1/n octave analysis

A further special case is the 1/n octave analysis (R&S®UPV-K6 option required), which is primarily used for acoustic measurements. In fractions of an octave, the bins of an FFT are combined in each case to yield a measurement value, where the fraction may be selected with an "n" value of 1, 3, 6, 12 or 24.

User-programmable filters adaptable to the measurement task at hand in a matter of seconds

The filters of the R&S®UPV are implemented as software. This enables the user to define as many as necessary, which is also beneficial for analog applications. The most common weighting filters are already included as standard. Additional filters can be programmed in only a few seconds after the type (lowpass, highpass, bandpass, bandstop, notch, third-octave or octave filter), frequency and attenuation have been entered.

Particularly in the case of special requests, the strengths of the instrument concept become readily apparent: Special filters can be calculated using commercially available filter design programs. The data record is transferred to the R&S®UPV and the required filter can be looped into the signal path.

As many as four filters can be combined.

Up to 256k points can be evaluated with the FFT analysis function; in the undersample mode, a frequency resolution of down to 0.2 mHz can be achieved.

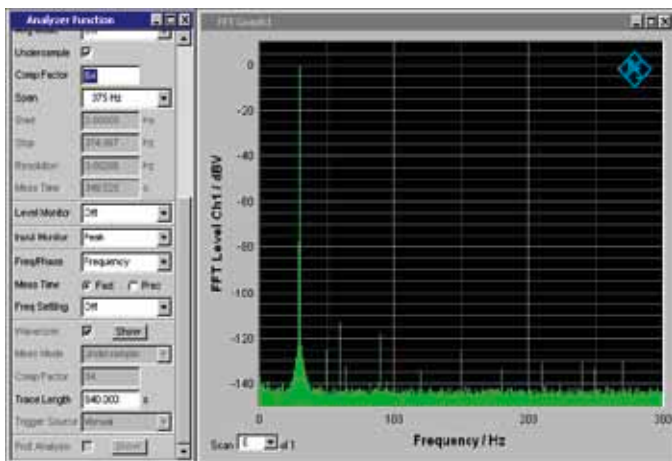

The FFT analysis function expands the THD+N measurement in this case; the automatic marking of the harmonics makes nonharmonic parts visible at a glance.

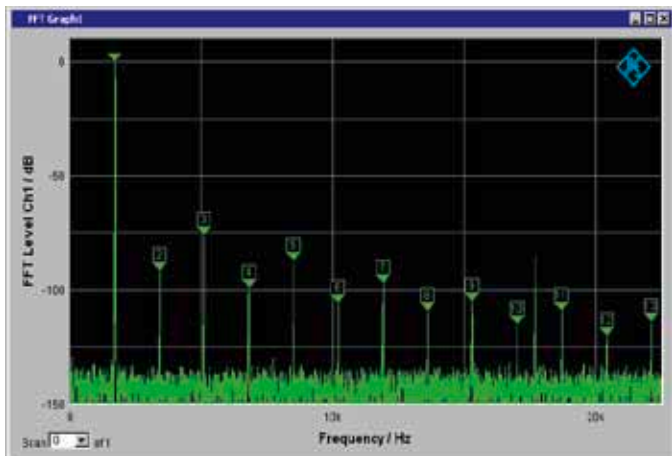

Everything included: no peripherals required

The R&S®UPV audio analyzer is a compact instrument that already contains an integrated PC. The disadvantages of audio analyzers that are controlled from an external PC can therefore be avoided.

The instrument is easy to transport, and no additional keyboard, monitor or other PC peripherals are needed.

The R&S®UPV comes ready to use right out of the box. Users only need to unpack it, switch it on and start measuring.

When an audio analyzer is operated using an external PC, the computer itself, the monitor or the interface connections can emit a level of disturbance that impedes the measurement of the audio DUT. In contrast, the R&S®UPV's EMC properties, including the integrated PC, have been tested and therefore meet all requirements placed on a measuring instrument. No conventional PC offers such extensive shielding measures, which include magnetically shielded AC power transformers or filter plates in front of the display.

Another aspect worth mentioning: The PC is included in the purchase price of the R&S®UPV

- Integrated hard disk and CD/DVD combo drive
- Connectors for keyboard, mouse, monitor and printer
- Four USB connectors
- LAN interface for connecting to networks
- Remote control via IEC/IEEE bus, USB or LAN
- Further processing of measurement data with standard software possible (Windows XP)
- All measurement results are available in common data formats, making the transfer of graphics, documents, etc., an easy task
- Easy addition of functions and software expansions in the future
- Automatic execution of measurement sequences or measurement routines by means of the universal sequence controller (see page 15)

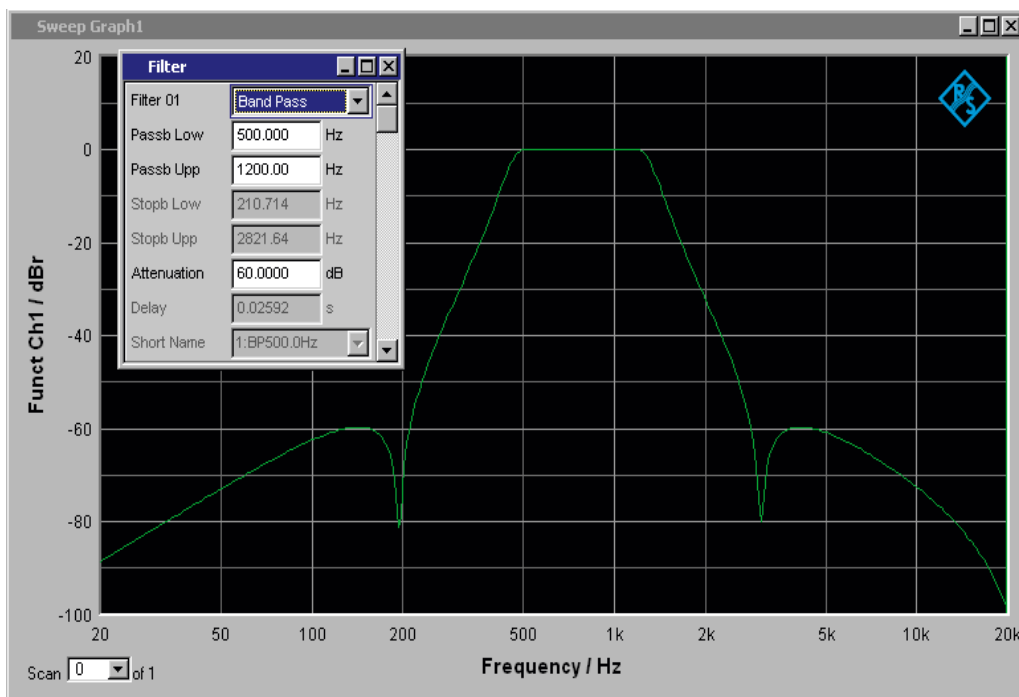

Filters can be programmed simply by entering a few parameters, which takes only a few seconds; they can be used both in the analyzer and the generator.

Largest variety of interfaces offered in a single instrument

Analog generator outputs as standard

- ▀ Balanced outputs, floating (e.g. for avoiding hum loops)
- ▀ The generator outputs can be connected internally to the analyzer inputs so that changes in measurement tasks can frequently be handled without any external recabling being necessary

Dual-channel analyzer with analog inputs as standard

- ▀ Dual-channel, balanced inputs with high common-mode rejection and various impedances that are common in studio equipment; lines with phantom powering can be measured
- ▀ Due to the wide dynamic range and the powerful autorange function, tests are possible even on class-D amplifiers without inserting expensive external filters, as is necessary with conventional audio analyzers

The analog analyzer can be expanded to 8 or 16 measurement channels (R&S®UPV-B48 option)

If the R&S®UPV-B48 eight-channel card is installed in one of the two slots on the rear, the R&S®UPV audio analyzer is transformed into a fast multichannel analyzer for surround-sound applications. Since this option can be installed in the other slot as well, up to 16 analog channels can be measured simultaneously.

With this option, it is also possible to perform measurements directly on class-D amplifiers without using expensive external filters.



Digital components with different data formats and clock rates are common in the world of professional audio equipment, which requires a measuring instrument that provides maximum performance at all interfaces.

Digital audio interfaces for professional studio operation and for the consumer electronics market (R&S®UPV-B2 option)

Digital audio equipment can be interconnected via standardized interfaces. With professional equipment, the AES/EBU format has become standard; with consumer equipment, the S/P DIF interface is used. The R&S®UPV-B2 option supports both areas:

- Balanced (XLR), unbalanced (BNC) and optical (TOSLINK) inputs and outputs for connecting consumer electronics equipment and professional studio equipment
- The level of the balanced and of the unbalanced output can be adjusted so that the sensitivity of digital audio inputs can be determined
- Simulation of long cable lengths by using an integrated cable simulator
- Adjustable phase shifting between digital audio and reference output
- The format of the generated channel status data can be selected independently of the selected interface, where the choices are "professional" and "consumer"
- Reference (XLR) and synchronization input (BNC) at the rear of the instrument; this allows the generator to be synchronized with the digital audio reference signal (DARS) in line with AES11, or with a word clock
- Bit- or word-synchronous sync signals are generated that permit an accurate representation of the digital audio signal on an oscilloscope (preamble, eye pattern, signal symmetry, superimposed noise, etc.)
- Generator and analyzer can be operated with clock rates of 32 kHz to 192 kHz; the generator can also generate these clocks internally

- The clock rates of the analyzer and the generator are independent of each other, which allows clock rate converters to be analyzed
- Audio words of 8 bit to 24 bit can be selected independently for the generator and the analyzer

Digital protocol analysis and generation (R&S®UPV-K21 option)

This software option expands the functions of the R&S®UPV-B2 option to include a conclusive analysis and the generation of additional digital data:

- Analysis of the channel status data; the data is output in binary format and evaluated on the basis of the professional or consumer format in line with AES3 or IEC 60958
- Generation of channel status data and of the validity bit; the channel status data can be entered either in binary format, hex format, or in the professional or consumer format in line with AES3 or IEC 60958
- Simultaneous measurement of the clock rate and display of interface errors that occur, e.g. parity errors
- Protocol analysis can be carried out simultaneously with other measurement functions

The screenshot shows the 'Dig Analyzer Protocol' window with two channels and error flags. Channel 1 is set to Consumer format, Linear PCM, Copyright, No pre-emph, Mode 0, General, No indication, Don't care, 44.1 kHz, Level II, 20 bits, Not indicated, and Not indicated. Channel 2 is set to Professional format, Linear PCM, Pre-emph 50/15, Not indicated, 48 kHz, Stereo, AES18, 24 bits audio, 24 bits, Not indicated, Undefined, Channel 1, Not a ref signal, Not indicated, and No scaling. Error flags for both channels show PCM, parity, lock, and CRC as green (OK) and validity as red (error).

Channel 1:				Channel 2:			
Parameter	Value	Unit	Setting	Parameter	Value	Unit	Setting
Format	0 / 0		Consumer	Format	0 / 0		Professional
Audio Mode	0 / 1		Linear PCM	Audio Mode	0 / 1		Linear PCM
Copy Bit	0 / 2		Copyright	Pre-emphasis	0 / 4..2		011 Pre-emph 50/15
Pre-emphasis	0 / 5..3		000 No pre-emph	Source Freq Lock	0 / 5		0 Not indicated
Chan Status Mode	0 / 7..6		00 Mode 0	Sample Frequency	0 / 7..6		10 48 kHz
Category Code	1 / 6..0		0000000 General	Channel Mode	1 / 3..0		0010 Stereo
L-bit	1 / 7		0 No indication	User Bits	1 / 7..4		0100 AES18
Source Number	2 / 3..0		0000 Don't care	Aux / Audio Bits	2 / 2..0		100 24 bits audio
Channel Number	2 / 7..4		0000 Don't care	Word Length	2 / 5..3		101 24 bits
Sample Frequency	3 / 3..0		0000 44.1 kHz	Alignment Level	2 / 7..6		00 Not indicated
Clock Accuracy	3 / 5..4		00 Level II	Multichannel Mode	3 / 7		0 Undefined
Max Word Length	4 / 0		0 20 bits	Channel Number	3 / 6..0		0000000 Channel 1
Word Length	4 / 3..1		000 Not indicated	Reference Signal	4 / 1..0		00 Not a ref signal
Orig Sample Freq	4 / 7..4		0000 Not indicated	Sample Frequency	4 / 6..3		0000 Not indicated
				Frequency Scaling	4 / 7		0 No scaling

The generation and analysis of protocol data in the digital data stream is extremely easy:

In addition to the binary data, the evaluated data is output in either professional or consumer format.

Jitter and interface test (R&S®UPV-K22 option)

This option enables the user to analyze the physical parameters of the digital audio interface. The R&S®UPV-K22 option expands the functionality of the R&S®UPV-B2 option.

Analysis

- Measurement of the jitter amplitude and display of the jitter signal in the frequency and time domains
- Measurement of the input pulse amplitude and of the sampling frequency
- Measurement of the phase between audio input and reference input
- Analysis of the common-mode signal of the balanced input (frequency, amplitude, spectrum, etc.)

Generation

- The clock of the output signal can be "jittered" by applying a sine or noise signal with variable amplitude
- A common-mode signal can be superimposed on the balanced output
- If digital audio data is generated, jitter or common-mode interferences can be superimposed on this data stream
- An input signal with jitter superimposed can be output jitter-free

Test of audio ICs with I²S interfaces (R&S®UPV-B41 option)

A close look at how the various modules and chips are interconnected inside such audio equipment reveals primarily serial digital data interfaces. For several years now, the inter-IC sound bus (I²S bus) has found widespread use.

It is used throughout the world for dual-channel, device-internal audio data transmission; numerous audio A/D and D/A converters support this format.

The R&S®UPV-B41 option, which is inserted at the rear of the base unit, provides the R&S®UPV audio analyzer with I²S interfaces for generator and analyzer. The transmit chip uses either internal (master) or external (slave) synchronization. This is important because in more complex systems with multiple transmitters and receivers, it must be possible to centrally generate the system clock to ensure interference-free data transmission. Depending on the application, I²S formats with different word lengths are used. The R&S®UPV-B41 option can be adjusted to all common word lengths of 16 bit, 24 bit and 32 bit, where the number of audio bits used can be adjusted independently of the word length. In addition to the standard I²S format, special formats are also supported.

The R&S®UPV-B41 is connected to the DUT via a 25-contact D-Sub male connector. A cable with a junction to seven BNC male connectors is available as the R&S®UP-Z3 option.

R&S®UPV-B41 option: I²S interface; R&S®UPV-B42 option: universal serial interface

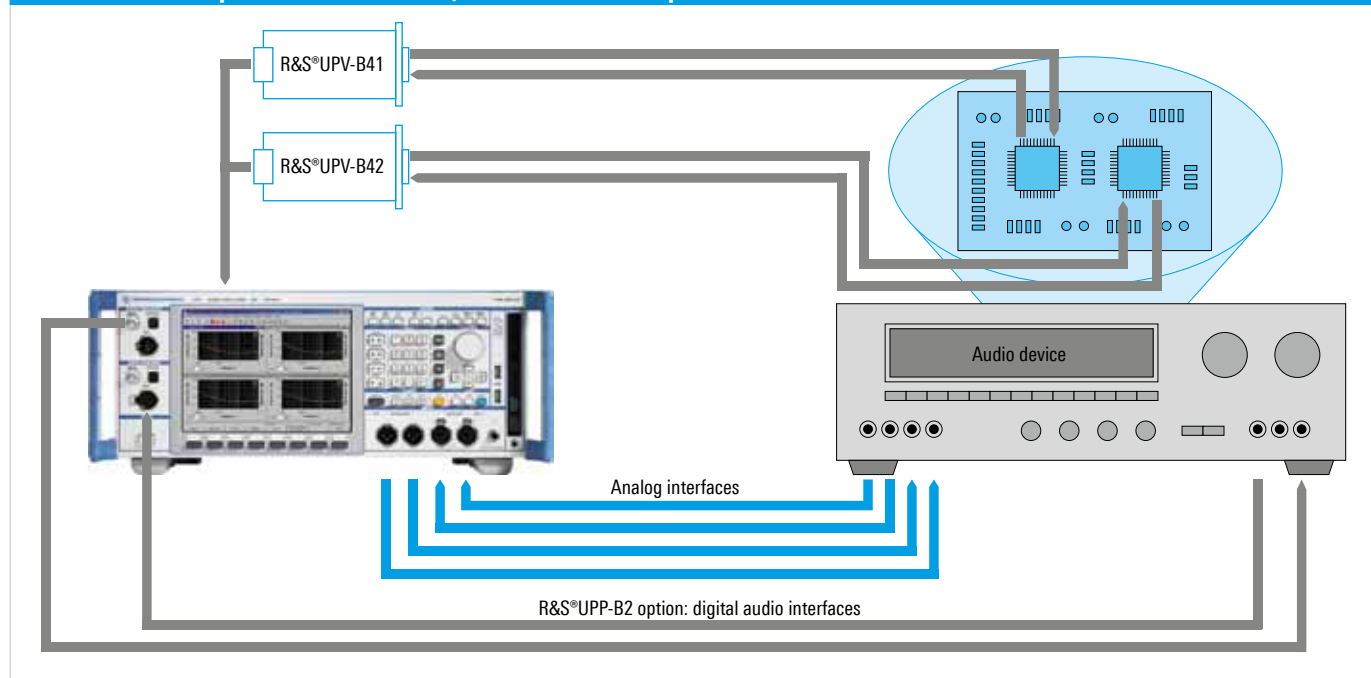

Virtually any audio circuit adaptable using the universal serial interface (R&S®UPV-B42 option)

Although numerous digital audio applications can use dual-channel data transmission, there is a strong trend toward formats that transmit more than two data channels. At the same time, numerous data formats are being developed. To accommodate all of these applications, the R&S®UPV-B42 universal serial interface option was developed. It can be inserted into one of the two slots on the rear of the R&S®UPV audio analyzer.

The generator and analyzer can be configured independently of each other, and they can be synchronized both internally and externally (master or slave mode). Up to four data lines can be handled; they can contain up to 256 audio data packets (slots) per frame in time multiplex. One or two test signals can be output simultaneously in any number of user-selectable slots, and up to eight audio signals from any number of user-selectable slots can be analyzed simultaneously. Data formats up to 32 bit can be processed with sampling rates of 1 kHz to 400 kHz. The bit sequence, slopes and offset can be flexibly adjusted. A detachable probe permits short, low-reflection connections directly to the chips to be tested; all common logic levels are supported. In summation, the user enjoys flexible digital audio interfaces that can be connected to practically all audio chips currently in use.

The R&S®UPV-B42 consists of plug-in card, connecting cable and probe (see figure).

PDM bitstream analysis (R&S®UPV-K421 option)

This software package expands the R&S®UPV-B42 option to include the measurement of digital audio signals that are transmitted in line with pulse density modulation method. This transmission mode is used, for example, for operating MEMS microphones; sigma delta converters also use this 1 bit data stream.

For both the generator and analyzer, all interfaces can be adjusted independently of one another, and they may be used together in any combination

The interfaces for the R&S®UPV generator and analyzer can be adjusted independently of one another. Therefore, DUTs with virtually any combination of interfaces can be tested. A/D and D/A converters can be directly connected. This is also true for complicated DSPs or format converters which, for example, require a 384 kHz clocked I²S format at the input and supply an AES/EBU signal with a sampling rate of 96 kHz to the analyzer.

In addition to the analog interfaces that are always present and the optional standard digital interfaces on the front panel of the R&S®UPV audio analyzer, two further interface cards can be plugged into the slots at the rear of the instrument. Therefore, up to four different interfaces can be made available in one instrument without any additional equipment being necessary.



Ever more complex chips demand a measuring instrument that can easily be adapted to a wide variety of data formats. The R&S®UPV audio analyzer, when used with the R&S®UPV-B42 option installed, is optimally designed for this requirement.

Convenient operation throughout

Operation can be learned in next to no time

The R&S®UPV features an intuitive user interface (with Windows XP as the operating system).

The large screen plays a key role, not only for displaying measurement results. All settings on the large screen are made in panels containing all interrelated functions and settings.

Five different screen displays are available. The user can switch between these "screens" merely by pressing a key. Each panel can therefore be quickly accessed without jamming the screen.

Panel size can be changed, and the panels may be moved to any position on the screen.

Basic settings of the instrument, such as audio interface configuration, are grouped in separate panels; once the settings are made, they can be hidden for the remaining measurement.

To make the user's task easier, only function blocks that are currently required are displayed; all other function blocks remain in the background. Example: Sweep parameters are not displayed in the generator panel until the sweep function has been selected.

The entire instrument can be operated from its front panel. The rotary knob plays a major role here. Users can move the cursor around inside a panel on the screen with only one hand and select a function by pressing the rotary knob. Numeric values can be varied directly by using the rotary knob, which is of enormous advantage when making adjustments.

Softkeys at the bottom of the screen permit fast access to changing functions, e.g. with graphical display.

The R&S®UPV can also be operated using an external keyboard and/or mouse.

The easy-to-understand operating concept (using the familiar Windows functions from the PC world) and the similar handling of analog and digital measurements allow users to quickly master instrument operation.

The large screen provides a straightforward display of all important settings and states of the R&S®UPV audio analyzer. Five virtual displays (screens) are available for better arrangement of the large number of possible panels and display windows.

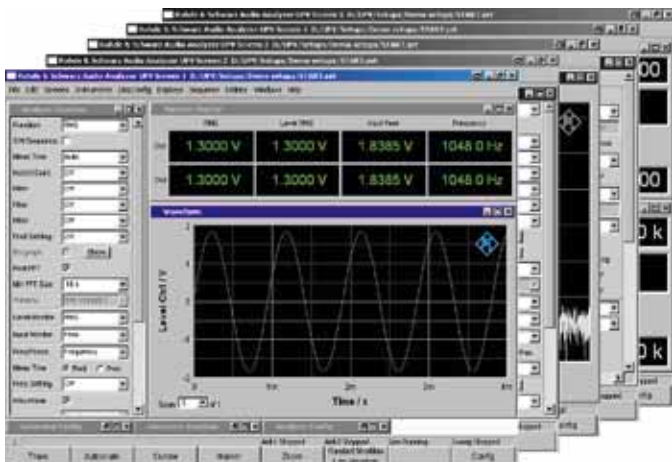

All measurement results at a glance

The measurement results for one or both channels and multiple measurement functions are displayed in realtime.

Scalable graphical windows can be arranged anywhere on the screen. When their size is changed, the labels, font sizes, grid lines, etc., are automatically adapted.

Multiple measurement diagrams are simultaneously available so that analysis in the frequency and time domains can be displayed simultaneously, for example.

With graphics, results can be read off using vertical and horizontal cursors, and limit lines or stored measurement results can be superimposed on them or compared with them. The graphical capabilities range from trace displays and bargraphs through to spectrum graphics.

By using color profiles, the user can determine the look of the measurement diagrams: The settings can be different for screen, printer and file output so that, for example, a black-and-white printer can be used alongside a screen with color display.

Effective online help functions

The R&S®UPV offers various help functions:

Context-sensitive help

HELP information either in German or English can be called up for any entry field by pressing a key.

When detailed information about a function is needed, the integrated user manual is available. The user can quickly navigate to the term in question by using the rotary knob or mouse.

Warning boxes

These boxes, which are clearly marked, alert the user to settings that may be incorrect.

Entry help

The permissible value range is displayed for every menu that may require the entry of a number. Furthermore, all higher-level parameters are taken into account, e.g. the sampling rate for measurements on digital interfaces.

Protection against operating errors

Entries outside the permissible value range are not accepted; such entries are automatically changed to their permissible minimum or maximum value.

Everything at a glance: Multiple measurement diagrams can be arranged in any manner preferred on the screen; analysis in the frequency and time domains can be displayed simultaneously.

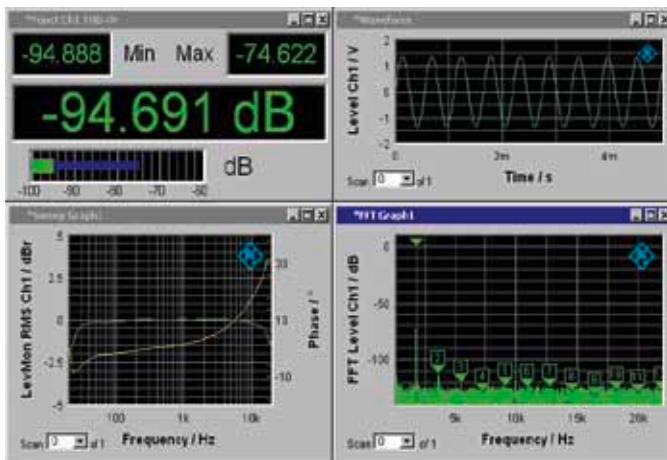

Graphics can be sized with vertical and horizontal cursors; markers and limit traces make evaluation easier. Multiple traces can be superimposed in user-defined colors; background colors, etc., can be selected to meet any requirement.

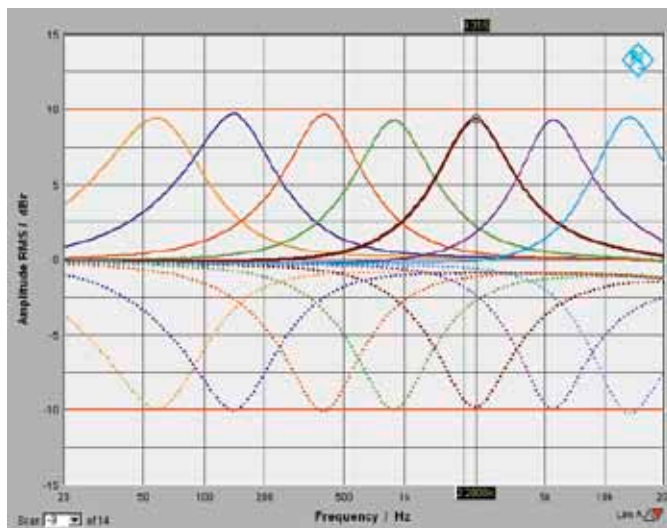

Powerful and fast

High measurement speed throughout the system

When the R&S®UPV audio analyzer was designed, special attention was paid to the speed of the overall measurement system:

- Time-critical and computation-intensive process steps are carried out by digital signal processors; the PC is largely used for instrument operation and to display results
- The R&S®UPV can also perform the complex measurement functions simultaneously on both channels; this alone cuts the time required for stereo measurements in half as compared with other analyzers on the market
- The digitally implemented measurement routines optimally adapt the measurement time to the input frequency; this yields a significant increase in measurement speed, particularly in the case of frequency sweeps
- Owing to digital signal processing, the internal setting and settling times can be kept shorter than with exclusively analog instruments. In addition, they are taken into consideration in the measurement routine. This yields stable measurements even without having to activate a settling function¹⁾

¹⁾ Settling function: Repetition of measurements until the measurement value consistently remains within a tolerance band.

The R&S®UPV66 – the special model for use in production systems – offers the full flexibility of the standard model.



High measurement speed, multichannel measurements and remote control capability are indispensable in production lines. The long calibration intervals of the R&S®UPV assure high availability and reduce operating costs.

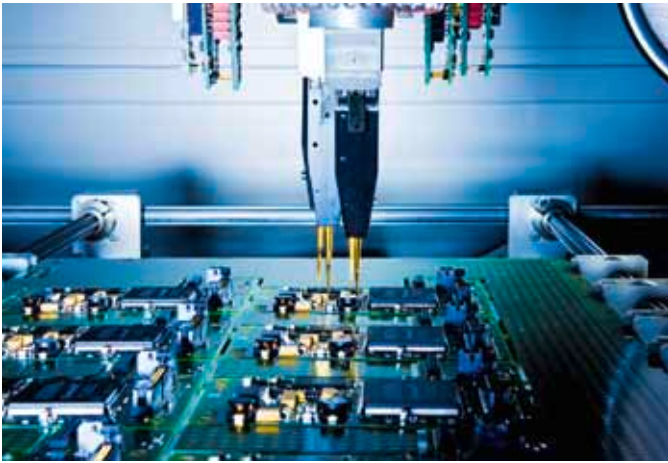

In the measurement of electro-acoustical converters, the test setup frequently includes measurement microphones and loudspeakers whose specific frequency response must be compensated for during the measurement. In this case, the filters and equalizer in the R&S®UPV are used.



Especially suitable for use in production

Measuring instruments for production tests must meet a large number of requirements:

- High measurement speed is crucial in order to achieve high production throughput. By making appropriate use of the instrument functions, Go/NoGo decisions can already be made in the R&S®UPV audio analyzer. This reduces the turnaround time for the DUT even further. Even complete parts of the analysis (macros) can be processed by the R&S®UPV
- Dual-channel measurements can, for example, also be used to determine input and output characteristics simultaneously, therefore saving time
- Up to 16 analog channels can be measured simultaneously. This saves a significant amount of time, such as when testing multichannel amplifiers
- The fast frequency response measurement achieved by using FFT analysis provides a critical edge particularly during the highly time-critical frequency response measurement (example: measurement of a frequency response with approx. 900 frequency values in 150 ms)
- Long calibration intervals owing to the large portion of digital T&M engineering contribute to high instrument availability
- Remote control capability over the IEC/IEEE bus is particularly indispensable in large production facilities. In the R&S®UPV audio analyzer, special attention was also paid to data traffic via the IEC/IEEE bus
- Especially in production scenarios, the R&S®UPV66 model is the optimum solution. The omission of a display, keypad and CD/DVD drive definitely saves money, yet the instrument can be manually operated at any time by attaching a monitor, PC keyboard and mouse. Therefore, the source of errors can be quickly located if any problems arise in production

R&S®UPV-K1 universal sequence controller

This option enables users to create and execute measurement sequences, turning the R&S®UPV into an automatic tester. As a result, small test systems can be implemented cost-effectively, since no additional control is required.

Every manual operating step is recorded in SCPI recording and then translated into a complete, syntactically correct command line. The command lines generated in this manner contain the instructions in a form that can be read (IEC/IEEE bus syntax in line with SCPI) and is not simply a sequence of pressed keys. This enables the user to set up user-defined measurement routines without having to look up the command syntax each time. This significantly reduces the effort necessary to create remote control routines and internally executed macros.

Options for further applications

R&S®UPV-B1 low distortion generator

The low distortion generator is required for all applications where extremely pure analog signals are necessary, or when an extended frequency range up to 185 kHz is needed. Its inherent distortion is lower than the excellent values for the universal generator.

R&S®UPV-B3 second analog generator

This hardware option provides the R&S®UPV with a second analog output amplifier. This also allows dual-channel sine-wave signals to be output on the two analog output channels. Furthermore, this option is required in order to generate the DIM signal and the squarewave signal, as well as to play stereo WAV files for PEAQ measurements.

Simultaneous pickup of measurement values for up to 16 analog channels with the R&S®UPV-B48 option (eight channels each)

This option can be installed in one or both of the slots at the rear. This makes the R&S®UPV audio analyzer a fast multichannel analyzer that can pick up as many as 16 analog channels simultaneously.

Two plug-in cards of the R&S®UPV-B4x option series can be operated simultaneously in the R&S®UPV, e.g. for measuring digital audio chips. In fact, two R&S®UPV-B48 options can be installed to process up to 16 analog measurement channels at the same time.



Fields of use include surround-sound applications or multi-channel amplifiers in the automotive sector. Simultaneous testing of multiple DUTs can also increase throughput in production.

The measurement channels are connected via a 25-contact D-Sub male connector to which conventional cable whips can be connected. A cable with a junction to eight XLR female connectors is available as the R&S®UPV-Z48 option.

R&S®UPV-B2 digital audio interface

This option contains the digital audio interfaces (balanced, unbalanced and optical) for the standard sampling rates of 32 kHz to 192 kHz. Pages 9 and 10 describe the option and its software expansions (R&S®UPV-K21 digital audio protocol and R&S®UPV-K22 jitter and interface test) in greater detail.

R&S®UPV-B41 I²S interfaces

The R&S®UPV-B41 option, which can be inserted at the rear of the base unit, provides the R&S®UPV with I²S interfaces for generator and analyzer. For further information, see page 10.

R&S®UPV-B42 universal digital interfaces

The R&S®UPV-B42 option expands the R&S®UPV audio analyzer by adding universal, digital audio interfaces with which the parameters of the digital formats can be set with great flexibility. Virtually all common audio chips can be connected.

R&S®UPV-K421 PDM bitstream analysis

The PDM bitstream analysis option makes it possible to analyze the audio contents of digital 1 bit data streams in PDM format.

For further information about R&S®UPV-B42 and R&S®UPV-K421, see page 11.

R&S®UPV-K6 extended analysis functions

The rub&buzz measurement enables users to determine production errors in loudspeakers in next to no time by measuring the interference signals in the frequency range above the usual distortion products.

The third-octave analysis and 1/n octave analysis are important measurements throughout the field of acoustics. The levels are determined simultaneously in up to 32 third-octave bands and 128 single-tone bands in line with the requirements of class 0 of IEC 1260. The undersample FFT (see page 6) is also part of this option.

The transfer and coherence functions are used to determine the transmission behavior of a DUT with the aid of music, speech or noise signals. The impulse response display is based on these functions.

These functions can also be used for measuring the inter-channel delay – for example, to determine the time delay of two channels during active transmission.

Speech and audio quality measurements: PESQ (R&S®UPV-K61 option), PEAQ (R&S®UPV-K62 option) and POLQA (R&S®UPV-K63 option)

Psycho-acoustic coding methods use the characteristics of the human ear and remove signal sections that have no effect on auditory perception before transmission. To develop suitable test methods, a large number of recorded audio samples with various speech and music examples were used.

These recordings were compressed using a variety of coders – and therefore different quality levels – and degraded by introducing typical network transmission interferences. A large number of test listeners rated these samples in a series of acoustic tests based on the standard scale for audio quality ranging from 1 (poor) to 5 (excellent).

The development of PESQ for speech signals and PEAQ for broadband audio signals provides methods that compare the original undegraded signals (reference signals) with the degraded signals (measurement signals) and then output objective measured values that correlate very well with the average of the listening test results. The latest method, POLQA, was developed primarily to handle the advanced coding and transmission methods for mobile phones. The R&S®UPV offers all these measurements in line with the methods licensed by the Opticom GmbH company in Erlangen, Germany.

Standard-compliant testing of hearing aids using the R&S®UPV-K7 and R&S®UPV-K71 options.



The measurement method referred to as the perceptual evaluation of speech quality (PESQ) was published in 2001 as Recommendation ITU-T P.862 by the International Telecommunication Union. It is used to measure the quality of speech signals that are transmitted at a low bit rate using high-compression psycho-acoustic coding methods (R&S®UPV-K61 option).

The measurement method referred to as the perceptual evaluation of audio quality (PEAQ) was published in 1998 as Recommendation ITU-R BS.1387 by the International Telecommunication Union. It is used to measure the quality of broadband audio signals (e.g. music) that are transmitted at a low bit rate using high-compression psycho-acoustic coding methods (R&S®UPV-K62 option). To measure dual-channel analog signals, the R&S®UPV-B3 option is additionally required.

Equipped with the R&S®UPV-K63 option, the R&S®UPV audio analyzer now also offers the measurement method referred to as the perceptual objective listening quality analysis (POLQA), which was published in 2011 as Recommendation ITU-T P.863 by the International Telecommunication Union. POLQA, a technology update to PESQ, was developed to meet the voice quality testing requirements of mobile network services. It offers measurements for higher transmission bandwidths and is also certified for acoustic measurements.

R&S®UPV-K7/-K71 software for hearing aid tests

After the R&S®UPV-K7 option has been installed in the R&S®UPV, the audio analyzer can test hearing aids in compliance with standards. The tests conform to IEC 60118 parts 0, 1, 2 and 7 as well as ANSI S3.22, therefore covering all specified tests.

If, in addition, measurements with speechlike test signals in line with IEC 60118 part 15 need to be performed, R&S®UPV-K7 can be extended with the R&S®UPV-K71 program package.

When necessary, the R&S®UPV-Z7 cable set for connecting the audio analyzer with an acoustic measurement chamber is available.

Further information is provided in the "Hearing aid measurements using the R&S®UPV Audio Analyzer" (PD 5214.5878.92) application brochure.

Acoustic measurements on mobile phones using the R&S®UPV-K9/-K91/-K92 option package

The acoustic transmission and reproduction quality of a mobile phone is the most important task in daily use. Therefore, this quality must be checked as part of quality assurance or sample checks during production, as well as for type approval.

The R&S®UPV audio analyzer and options described here determine the acoustic characteristics of these phones as specified by the bodies responsible for acoustic tests in the type approval of mobile phones. The tests are checked and validated by an independent test house.

The package of options for mobile-phone measurements with the R&S®UPV audio analyzer consists of the R&S®UPV-K9 base software package and modules for the individual standards (R&S®UPV-K9x).

The R&S®UPV-K91 option covers all tests for UMTS and GSM phones in line with 3GPP TS 26.132. The R&S®UPV-K92 option is required when measuring CDMA2000® phones in line with the TIA-1042 and 3GPP2C.S0056-0 standards.

Operation always requires a combination of R&S®UPV-K9 and at least one of the R&S®UPV-K9x options; for detailed information, refer to the “Acoustic Measurements on Mobile Phones” (PD 5214.5884.92) application brochure.

R&S UPV-K4 remote control option

This option enables users to operate the R&S®UPV by remote control over either a LAN, USB or IEC/IEEE bus interface in line with IEC 625/IEEE 488. The commands used conform to the SCPI guidelines to the extent possible.

R&S®UPV-K1 universal sequence controller

This option enables users to create and execute measurement sequences, turning the R&S®UPV into an automatic tester. As a result, small test systems can be implemented cost-effectively, since no additional control PC is required. For further information, refer to page 15.

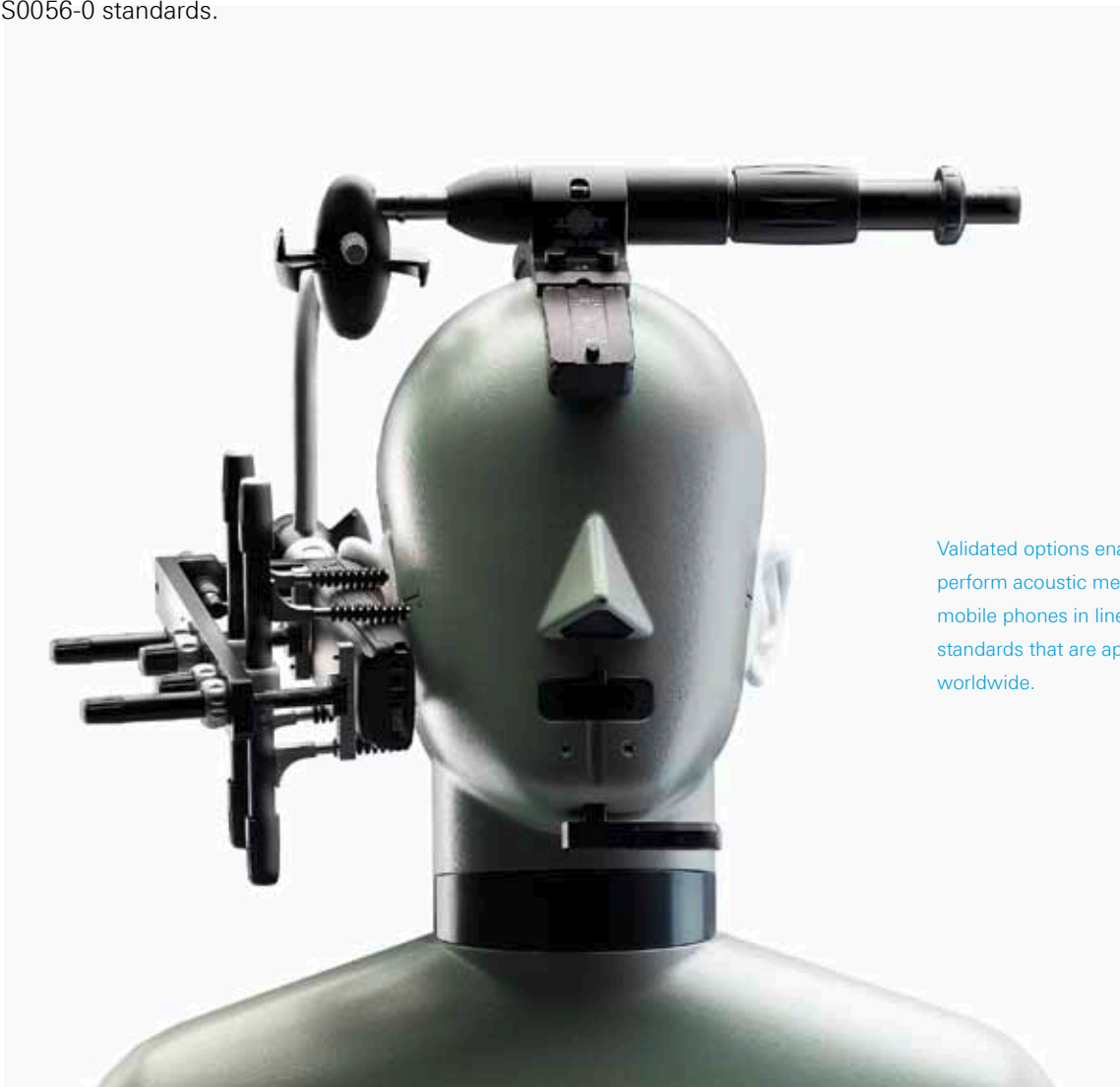

Validated options enable users to perform acoustic measurements of mobile phones in line with standards that are applicable worldwide.

R&S®UPV-U1 150 Ω modification

The modification changes the source impedance of the analog generators from 200 Ω to 150 Ω.

BNC monitoring outputs

The standard audio monitoring output includes a head-phone output and an integrated loudspeaker via which the input signal as well as filtered or weighted signals can be monitored. Optionally, the available connectors can be expanded to include two BNC female connectors by adding the R&S®UPV-U2 option. It then becomes possible to connect an oscilloscope, for example.

R&S®UP-Z1MF XLR/BNC adapter set

Two XLR male to BNC and two XLR female to BNC adapters make the use of unbalanced cables easier.

Connecting cables

The R&S®UPV-B41 and R&S®UPV-B48 options are fitted with 25-contact D-Sub connectors.

- The R&S®UP-Z3 I²S cable routes the RX Data, RX BitClk, RX FSync, TX Data, TX BitClk, TX FSync and TX MasterClk lines from the D-Sub connector to separate BNC male connectors
- The R&S®UPV-Z48 cable for connecting the eight analog measurement channels of the R&S®UPV-B48 provides the junction from D-Sub to eight XLR female connectors

Audio switcher

If multiple DUTs/channels have to be connected by means of cables such as during production, the R&S®UPZ audio switcher is the solution. The switcher is connected directly to the R&S®UPV audio analyzer and is operated from the control panel via an RS-232-C interface. The eight-channel R&S®UPZ is available as an input version and output version, and it can be cascaded to support up to 128 channels.

Further information is provided in the “R&S®UPZ Audio Switcher” (PD 0758.1170.32) data sheet.

R&S®UP-Z1MF XLR/BNC adapter set.



R&S®UPV-Z48 and R&S®UP-Z3 connecting cables.



The R&S®UPZ audio switcher can be controlled directly from the R&S®UPV.



Specifications in brief

Specifications in brief		
Dual-channel analog analyzer		
Inputs, 2 channels	XLR female, balanced (unbalanced measurements possible with R&S®UP-Z1MF XLR/BNC adapter) XLR pin 1 floating/grounded selectable, AC/DC coupling selectable	
Frequency range	bandwidth 22 kHz/40 kHz/80 kHz/250 kHz	DC/10 Hz to 21.76 kHz/40 kHz/80 kHz/250 kHz
Voltage range	RMS, sine	0.1 µV to 110 V
Measurement functions	base unit	RMS wideband, RMS selective, peak, quasi-peak, S/N, DC, FFT, THD, THD+N, SINAD, Mod Dist, DFD, DIM, polarity, waveform, frequency, phase, group delay
	R&S®UPV-K6 option	rub&buzz, 1/n octave analysis, undersample FFT, impulse response, transfer and coherence, inter-channel delay
	R&S®UPV-K61 option	PESQ
	R&S®UPV-K62 option	PEAQ, impulse response, transfer and coherence, interchannel delay
	R&S®UPV-K63 option	POLQA
Eight-channel analog inputs (R&S®UPV-B48 option)		
Inputs, 8 channels	25-contact D-Sub female balanced, AC/DC coupling selectable	
Frequency range	DC/20 Hz to 40 kHz	
Voltage range	RMS, sine	0.1 µV to 50 V
Measurement functions	RMS wideband, RMS selective, peak, S/N, DC, FFT, THD, THD+N, SINAD, Mod Dist, DFD, DIM, polarity, waveform, frequency, phase, group delay	
Analog generator		
Outputs, 2 channels	XLR male, floating/grounded, balanced/unbalanced, short-circuit-proof	
Voltage	balanced, RMS, sine, open circuit	0.1 mV to 20 V
	unbalanced, RMS, sine, open circuit	0.1 mV to 10 V
Frequency range	base unit, sine	0.1 Hz to 80 kHz
	R&S®UPV-B1 option, sine	10 Hz to 185 kHz
Output signals	base unit	sine, multisine, sine burst, sine ² burst, Mod Dist, DFD, noise, arbitrary waveform, polarity, FM, AM, DC, play WAVE files
	R&S®UPV-B3 option	stereo sine, DIM, square
Digital analyzer/generator		
Digital audio interfaces (R&S®UPV-B2 option)		
Connectors	balanced	XLR female/male, transformer coupling, 110 Ω
	unbalanced	BNC, grounded, 75 Ω
	optical	TOSLINK
Channels	1, 2 or both	
Audio bits	8 bit to 24 bit	
Sampling rate	30 kHz to 200 kHz	
Format	professional and consumer format in line with AES3 and IEC 60958	
Output signals/measurement functions	R&S®UPV-B2 option	same as with analog device
	R&S®UPV-K21 option	digital audio protocol
	R&S®UPV-K22 option	jitter, common mode
I²S interface (R&S®UPV-B41 option)		
Connector	25-contact D-Sub male, BNC for external sync clock signal	
Channels	1, 2 or both	
Word length	16/24/32 bit per channel	
Audio bits	8 bit to 32 bit	
Sampling rate	6.75 kHz to 400 kHz	
Output signals/measurement functions	same as with analog device	

Specifications in brief

Universal serial interface (R&S®UPV-B42 option)

Interface		probe with female connector strips
Data lines		1 to 4
Channels		1 or 2 signals in up to 256 slots per frame
Slot length		8 bit to 256 bit
Audio bits		8 bit to 32 bit
Sampling rate		0.85 kHz to 400 kHz
Operating modes		master, slave with numerous sync modes
Output signals/measurement functions		same as with analog instrument, plus jitter generation

Universal serial interfaces with PDM bitstream analysis (R&S®UPV-K421 option)

Measurement channels	channel mode: mono	1 to 4 mono channels (data lines 1 to 4)
	channel mode: stereo	1 to 2 stereo channels (data lines 1 and 2)
Bitstream clock rate		512 kHz to 12.8 MHz
Bitstream clock duty cycle		40 % to 60 %
Downsampling factor		64/128/256
Sampling rate		2 kHz to 200 kHz
Audio bits		8 bit to 32 bit
Measurement functions		same as with analog analyzer

FFT analysis

Frequency range	digital	DC to 0.5 × sampling rate
	analog, bandwidth 22 kHz/40 kHz/80 kHz/250 kHz	DC to 22.5 kHz/43.5 kHz/87 kHz/250 kHz
Dynamic range	digital, R&S®UPV-B2 option	170 dB
	digital, R&S®UPV-B41/-B42 option	220 dB
	analog, bandwidth 22 kHz/40 kHz/80 kHz	120 dB
	analog, bandwidth 250 kHz	100 dB
Noise floor	digital, R&S®UPV-B2 option	-170 dB
	digital, R&S®UPV-B41/-B42 option	-220 dB
	analog, bandwidth 22 kHz/40 kHz/80 kHz	-140 dB
	analog, bandwidth 250 kHz	-120 dB
FFT length		512, 1k, 2k, 4k, 8k, 16k, 32k, 64k, 128k, 256k points
Window functions		rectangle, Hann, Blackman-Harris, Rife-Vincent 1-3, Hamming, flat-top

Filters

Weighting filters	A weighting, C weighting, CCIR 1k weighted, CCIR 2k weighted, CCIR unweighted, CCITT, C message, DC noise highpass, deemphasis J.17, 50/15, 50, 75, preemphasis 50/15, 50, 75, IEC tuner, jitter weighted, rumble weighted, unweighted, highpass 22 Hz, 400 Hz, lowpass 22 kHz, 30 kHz, 80 kHz, AES 17	
User-definable filters	design parameters	8th order elliptical type C (for highpass and lowpass also 4th order selectable), stopband attenuation up to approx. 120 dB selectable
	types of filters	highpass, lowpass, bandpass, bandstop, notch, third-octave and octave filter
	file-defined filters	any 8th order filter cascaded from 4 biquads, defined in the z plane by poles/zeros or coefficients

General data

Rated voltage		100 V/120 V/220 V/230 V, 50 Hz to 60 Hz, 300 VA
Dimensions	W × H × D	465 mm × 197 mm × 495 mm (18.31 in × 7.76 in × 19.49 in)
Weight	with all options	15.0 kg (33.07 lb)

For data sheet, see PD 0758.1306.22 and www.rohde-schwarz.com

Ordering information

Designation	Type	Order No.
Base unit		
Audio Analyzer	R&S®UPV	1146.2003.02
Audio Analyzer, without display	R&S®UPV66	1146.2003.66
Accessories supplied		
Power cable		
Compact manual		
CD with operating manual/service manual		
Hardware options		
Low Distortion Generator	R&S®UPV-B1	1146.5202.02
Digital Audio Interfaces AES/EBU, S/P DIF	R&S®UPV-B2	1146.4306.02
Second Analog Generator	R&S®UPV-B3	1146.4806.02
I ² S Interface	R&S®UPV-B41	1146.5402.02
Universal Serial Interface	R&S®UPV-B42	1146.5802.02
Eight-Channel Analog Inputs	R&S®UPV-B48	1402.2200.02
Modification 150 Ω	R&S®UPV-U1	1146.1507.02
BNC Phone Out	R&S®UPV-U2	1402.1704.02
Software options		
Universal Sequence Controller	R&S®UPV-K1	1401.7009.02
Digital Audio Protocol	R&S®UPV-K21	1401.7809.02
Jitter and Interface Test	R&S®UPV-K22	1401.7909.02
Remote Control	R&S®UPV-K4	1401.9001.02
PDM Bitstream Analysis	R&S®UPV-K421	1402.1104.02
Extended Analysis Functions	R&S®UPV-K6	1401.9201.02
Software for PESQ Measurement	R&S®UPV-K61	1401.7309.02
Software for PEAQ Measurement	R&S®UPV-K62	1401.7750.02
Software for POLQA Measurement	R&S®UPV-K63	1402.1156.02
Software for Hearing Aid Measurements	R&S®UPV-K7	1401.9301.02
Hearing Aid Speech Tests	R&S®UPV-K71	1402.1004.02
Base Software for Mobile Phone Tests	R&S®UPV-K9	1402.0008.02
UMTS/GSM Mobile Phone Tests	R&S®UPV-K91	1402.0108.02
CDMA2000® Mobile Phone Tests	R&S®UPV-K92	1402.0608.02
System components		
Cable Set for R&S®UPV-K7	R&S®UPV-Z7	1401.7609.02
Cable for R&S®UPV-B48	R&S®UPV-Z48	1401.7709.02
XLR/BNC Adapter Set, 2 male, 2 female	R&S®UP-Z1MF	1411.3306.02
I ² S Cable for R&S®UPV-B2/UPV-B41	R&S®UP-Z3	1411.3458.02
19" Rack Adapter	R&S®ZZA-411	1096.3283.00
Audio Switcher (Input)	R&S®UPZ	1120.8004.12
Audio Switcher (Output)	R&S®UPZ	1120.8004.13

Service options		
Two-Year Calibration Service	R&S®CO2UPV	Please contact your local Rohde & Schwarz sales partner.
Three-Year Calibration Service	R&S®CO3UPV	
Five-Year Calibration Service	R&S®CO5UPV	
Repair Service for One Year Following Product Warranty	R&S®RO2UPV	
Repair Service for Two Years Following Product Warranty	R&S®RO3UPV	
Repair Service for Four Years Following Product Warranty	R&S®RO5UPV	

¹⁾ CDMA2000® is a registered trademark of the Telecommunications Industry Association (TIA-USA).

Service you can rely on

- | Worldwide
- | Local and personalized
- | Customized and flexible
- | Uncompromising quality
- | Long-term dependability

About Rohde & Schwarz

Rohde & Schwarz is an independent group of companies specializing in electronics. It is a leading supplier of solutions in the fields of test and measurement, broadcasting, radiomonitoring and radiolocation, as well as secure communications. Established more than 75 years ago, Rohde & Schwarz has a global presence and a dedicated service network in over 70 countries. Company headquarters are in Munich, Germany.

Environmental commitment

- | Energy-efficient products
- | Continuous improvement in environmental sustainability
- | ISO 14001-certified environmental management system

Certified Quality System
ISO 9001

Rohde & Schwarz GmbH & Co. KG

www.rohde-schwarz.com

Regional contact

- | Europe, Africa, Middle East
+49 89 4129 123 45
customersupport@rohde-schwarz.com
- | North America
1 888 TEST RSA (1 888 837 87 72)
customer.support@rsa.rohde-schwarz.com
- | Latin America
+1 410 910 79 88
customersupport.la@rohde-schwarz.com
- | Asia/Pacific
+65 65 13 04 88
customersupport.asia@rohde-schwarz.com

R&S® is a registered trademark of Rohde & Schwarz GmbH & Co. KG

Trade names are trademarks of the owners | Printed in Germany (sv)

PD 0758.1306.12 | Version 04.00 | July 2011 | R&S®UPV

Data without tolerance limits is not binding | Subject to change

© 2004 - 2011 Rohde & Schwarz GmbH & Co. KG | 81671 München, Germany



0758130612