

## Audio Analyzer R&amp;S®UPV

Interface for the I<sup>2</sup>S serial data bus

The compact Audio Analyzer R&S®UPV smoothly handles any audio measurement. With features that are as advanced as technically possible, it is predestined for high-resolution digital media and meets the stringent requirements of analog technology [\*].

By means of two rear extension slots, it can be adjusted to rapidly changing technical developments. Brand-new is the interface extension for the I<sup>2</sup>S bus, which is gaining ground worldwide. This option allows direct audio measurements on a wide variety of components and modules with maximum precision.

### The R&S®UPV: always state-of-the-art

Today, we take it for granted that digital audio equipment can be interconnected via standardized interfaces. With professional equipment, the AES/EBU format has become standard; with consumer equipment, the S/P DIF interface is used.

However, if you take a close look at how individual modules and components are interconnected inside such audio equipment, you will usually find other serial data interfaces. Over the last few years, a serial data bus referred to as the inter-IC sound bus (I<sup>2</sup>S bus) has been gaining ground. This digital interface is often used throughout the world for dual-channel, device-internal audio data transmission; numerous audio A/D and D/A converters support this format.

The Audio Analyzer R&S®UPV with its new I<sup>2</sup>S Interface R&S®UPV-B41 is even more versatile. It can be inserted at the rear and adds new audio interfaces. This new option enables the R&S®UPV to perform measurements directly on digital audio components, making it a compact development tool that is unique in its class.

### The I<sup>2</sup>S format in detail

Three signals have been defined as standard for the I<sup>2</sup>S interface: SCK (bit clock), FSYNC (frame synchronization) and DATA (FIG 1). SCK (often also referred to as BCLK) is the bit clock of this interface. One audio data bit is transmitted with each clock period. DATA is a dual-channel, multiplexed, bit-serial data stream. FSYNC (often also referred to as LRCLK)

FIG 1 Top: Basic signal characteristic at the I<sup>2</sup>S interface. Bottom: For measurements with reduced resolution, the number of audio bits can be set between eight and 32 in a data word; the remaining data bits in the generator are set to zero.

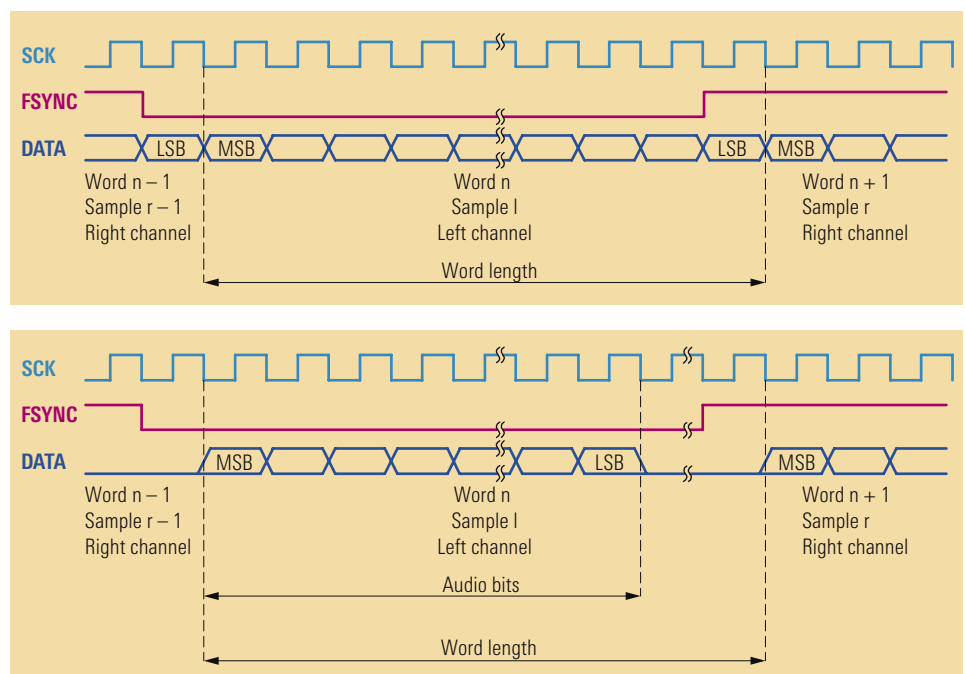



44 176/5

**FIG 2** The Audio Analyzer R&S®UPV with its new I<sup>2</sup>S Interface R&S®UPV-B41 is even more versatile (measurement on a digital audio module shown here).

marks the beginning of a word in the serial data stream and differentiates the left from the right channel.

The receiver clocks in the FSYNC and DATA signals at each rising edge of the SCK signal. The transmitter changes these signals at the falling edge. Thus, you obtain virtually ideal sampling in the center of a bit window, making the transmission immune to any skew of individual signals.

In the simplest scenario, a transmission component generates clock, frame synchronization and data. In more complex systems with several transmitters and receivers, it may be necessary to centrally generate the system clock

to ensure interference-free data transmission. For this reason, the I<sup>2</sup>S interface for the R&S®UPV uses either internal (master) or external (slave) synchronization.

Special to the I<sup>2</sup>S format is that the FSYNC edge transition already occurs one clock before the transmission of the first data bit of a word. This offset permits synchronous switching logic in a transmitter that is operated as a slave. Serial data is transmitted with MSB first. Two's complement is used as the numerical format.

Depending on the application, I<sup>2</sup>S formats with different word lengths are used. The R&S®UPV-B41 can be set to

I<sup>2</sup>S data streams with all usual word lengths of 16 bits, 24 bits and 32 bits.

### Audio measurements with maximum precision

FIG 2 shows a typical application of the audio analyzer with the I<sup>2</sup>S interface: To evaluate a digital audio circuit, the DUT is connected directly with the analyzer. The data word length of up to 32 bits helps to achieve unprecedented spectral purity, making it possible to perform audio measurements with maximum precision (FIG 3).

If audio data streams with reduced resolution are to be tested in high-resolution ▶

- ▶ I<sup>2</sup>S formats, the number of audio bits in a data word can be set between eight and 32, while the remaining data bits in the generator are set to zero (FIG 1). For the measurement, the analyzer evaluates only the selected number, starting from the MSB.

The sampling rates of the generator and the analyzer can be set individually. Plus, all audio interfaces in the R&S®UPV – both in the analog and the

digital domain – can be activated individually. Thus, a wide variety of modules and components such as A/D and D/A converters, DSPs, sampling rate converters, format converters and numerous other interface components can be directly connected. Some of these components require a master clock that is an integer multiple of the FSYNC signal. The R&S®UPV can either generate this master clock or synchronize itself to it.

## Summary

With the new I<sup>2</sup>S Interface R&S®UPV-B41 option and the R&S®UPV-B2 option for sampling rates up to 192 kHz (which has been available since the R&S®UPV 's market launch), the Audio Analyzer R&S®UPV covers a major part of analog and digital audio measurements. Other interfaces are in the pipeline.

Norbert Hersch

### Important abbreviations

AES/EBU	Audio Engineering Society / European Broadcasting Union
BCLK	Bit clock
FSYNC	Frame synchronization
I <sup>2</sup> S	Inter-IC sound bus
LRCLK	Left right clock
LSB	Least significant bit
LVTTTL	Low voltage TTL
MSB	Most significant bit
SCK	Serial clock
S/P-DIF	Sony/Philips digital interface format

**FIG 3**  
Data word lengths up to 32 bits for audio measurements with maximum dynamic range.

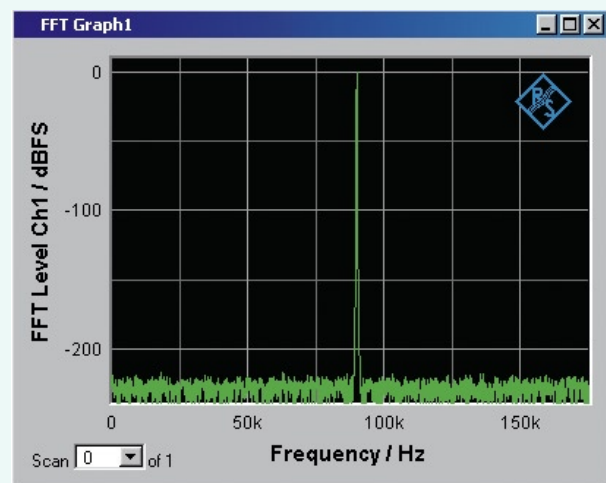

More information and data sheet at  
[www.rohde-schwarz.com](http://www.rohde-schwarz.com)  
(search term: UPV)



#### REFERENCES

- [\*] Audio Analyzer R&S®UPV: The benchmark in audio analysis. News from Rohde & Schwarz (2004) No. 183, pp 16–20

### Condensed data of the I<sup>2</sup>S Interface R&S®UPV-B41

#### Input

Level	low: <0.8 V (min. -5 V) high: >2 V (max. 10 V)
Word length	16 / 24 / 32 bits / channel
Audio bits	8 to 32
Word clock	6.75 kHz to 400 kHz

#### Output

Level	LVTTTL
Word length	16 / 24 / 32 bits per channel
Audio bits	8 to 32
Word clock	6.75 kHz to 400 kHz
Synchronization	internal clock; external word clock or master clock
Master clock	432 kHz to 51.2 MHz