

TV Test Transmitter SFQ

Test signals for DVB-T diversity reception

To test diversity receivers, two or more RF signals have to be applied to the various antenna inputs. In order that these signals represent the real receive situation, however, special conditions must be fulfilled. A new option for the TV Test Transmitter SFQ (FIG 1) generates signals which optimally suit these requirements.



Photo 43666/2

FIG 1 With the new optional Noise Generator SFQ-B5, the SFQ can generate signals for testing diversity receivers

Unrivalled method for testing DVB-T diversity reception

The change to digital terrestrial TV (DVB-T) has greatly advanced in many European countries. In Germany, a decision has been made in favour of DVB-T and implementation will soon take place. While stationary reception via a directional roof antenna was envisaged at first, the so-called portable in-house method will finally be used in Germany. In this case, the receive antenna is integrated in the TV set or the signals are received by a room antenna. Experience has shown that certain modes of the DVB-T standard are suitable for mobile radio reception (combination of various system parameters, e.g. QPSK or 16QAM, code rate 1/2 or 2/3). According to the current line of thinking, it can be

assumed that reception in vehicles (cars, trams, trains, etc) will be possible wherever portable in-house reception can be realized.

This attractive extension of the application field is mainly due to new, innovative receiver concepts. Receivers using diversity reception, i.e. those which intelligently combine signals from two or more antennas, are the most promising. Diversity reception is particularly suitable in cars where various input signals are received by different windshield antennas.

From a technical point of view, the benefit of diversity reception can be described as a simplification of the receive situation where Rayleigh channels are often converted to Rice chan-

FIG 2
Depending on the number of signals required, two or more TV Test Transmitters SFQ can be connected

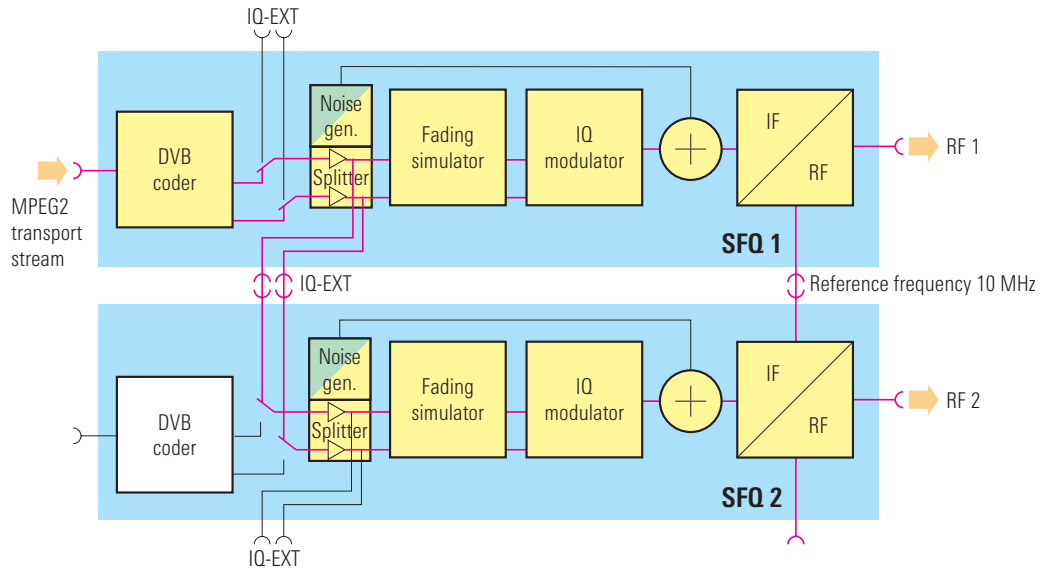

nels so that the receivers can operate with a considerably lower S/N ratio. When diversity antennas are used, a much higher location probability (and presumably also a higher time probability) can be expected for the coverage of an area in comparison to conventional methods.

Test setup

To test diversity receivers, two or more RF signals have to be applied to the various antenna inputs. To represent the real receive situation, the signals must have the same RF frequency and use bit-synchronous data transmission, but they must be completely uncorrelated (i. e. different in amplitude and phase) in the simulated transmission channels. This corresponds to a receive situation where the receive antennas differ by at least half a wavelength.

The new optional Noise Generator SFQ-B5 [*] for the TV Test Transmitter SFQ generates signals which meet all these requirements. Bit synchronization of data is guaranteed because only one DVB-T coder is used, the I/Q output signals of which are then processed by two or more units. A 0 dB splitter is therefore

provided in this option. The first outputs of the splitter are internally connected to the fading simulator; the second outputs are implemented as a connector pair so that several SFQs can be combined (FIG 2).

The fading simulators are normally set to the same fading patterns (paths). Due to the internal random processes used in this case, the required uncorrelated RF signals are obtained.

To synchronize the RF output frequencies, an SFQ acting as the master generates an internal 10 MHz reference frequency to which the reference frequencies of the other units are synchronized. A laboratory test setup is thus obtained in which real and repeatable test scenarios for the development of DVB-T diversity receivers can be created.

This unique method was successfully used for measurements within the EU development project MOTIVATE to demonstrate the efficiency of various diversity receivers. Comparisons with field measurements suggest that this test setup is able to handle the most complex situations in the practice.

Dr Jürgen Lauterjung

More information and data sheet at
www.rohde-schwarz.com
(search for SFQ)

Data sheet SFQ



The DTV Dream Team CD can be obtained free of charge from any Rohde & Schwarz representative.

REFERENCE

[*] TV Test Transmitter SFQ – High-precision internal noise source enhances measurement functions. News from Rohde & Schwarz (2001) No. 170, pp 37–38