

Use of Measurement Decoder DVMD for quality control by Swiss broadcaster

Broadcasters are increasingly turning to digital technology for better management of resources and the spectrum. When a broadcaster today decides in favour of satellite transmission, this will be in line with **DVB and MPEG2 standards** – at least in Europe. This means that the signal must be conditioned, compressed and multiplexed before it can be modulated and sent to

the satellite. At this point the question of measurement and quality arises. Is the signal delivered to the satellite error-free? Analog technology is no longer suitable for this purpose. In analog pictures interference like noise is visible immediately. In the case of signals sent to a satellite at 38 Mbit/s measurement is much more complicated. Digital technology can be deceptive because you suppose everything to be normal when you hear the sound or see the picture. Conventional monitoring is obviously insufficient. To determine whether everything is as it should be in an MPEG2 digital signal, you have to ana-

lyze the signal structure and examine the sections in which video and audio information is transported [1].

Choice of instrument

The MPEG2 standard and its principles are very complex, so it could take months to analyze and check the contents of an MPEG2 stream. The broadcaster, however, must guarantee error-free signals throughout. Furthermore, after installation a DVB transmission system may be operated and monitored by staff who are not necessarily specialized in MPEG2. For these reasons the Swiss broadcaster SRG-SSR decided to use **MPEG2 Measurement Decoder DVMD** [2] as a realtime test instrument (FIG 1). It takes continuous analysis of the signals transferred to the Hot Bird 3 satellite to ensure correct operation of the equipment. This round-the-clock analysis by means of DVMD actually enabled the supplier of the DVB-S system to improve it, since SRG-SSR was the first broadcaster to permanently analyze the signal, and thus equipment errors and instabilities could be detected. No compromise was made: the signal had to conform fully to MPEG2 standard.

For an optimum grip on the origin of faults, SRG-SSR decided in favour of a measurement principle that ensures the following **requirements** are met:

- The signal emitted must conform to the standard.
- The signal received from the satellite and passed on to the viewers must be absolutely errorfree (1st and 2nd priority).

FIG 2 shows the implementation, requiring two DVMDs. It ensures that the signals transmitted (output by the main multiplexer) and the signals received are conformal. In case of problems SRG-SSR can quickly deter-

FIG 1 Measurement Decoder DVMD for analysis of MPEG2 transport streams

Photo 43 179/5

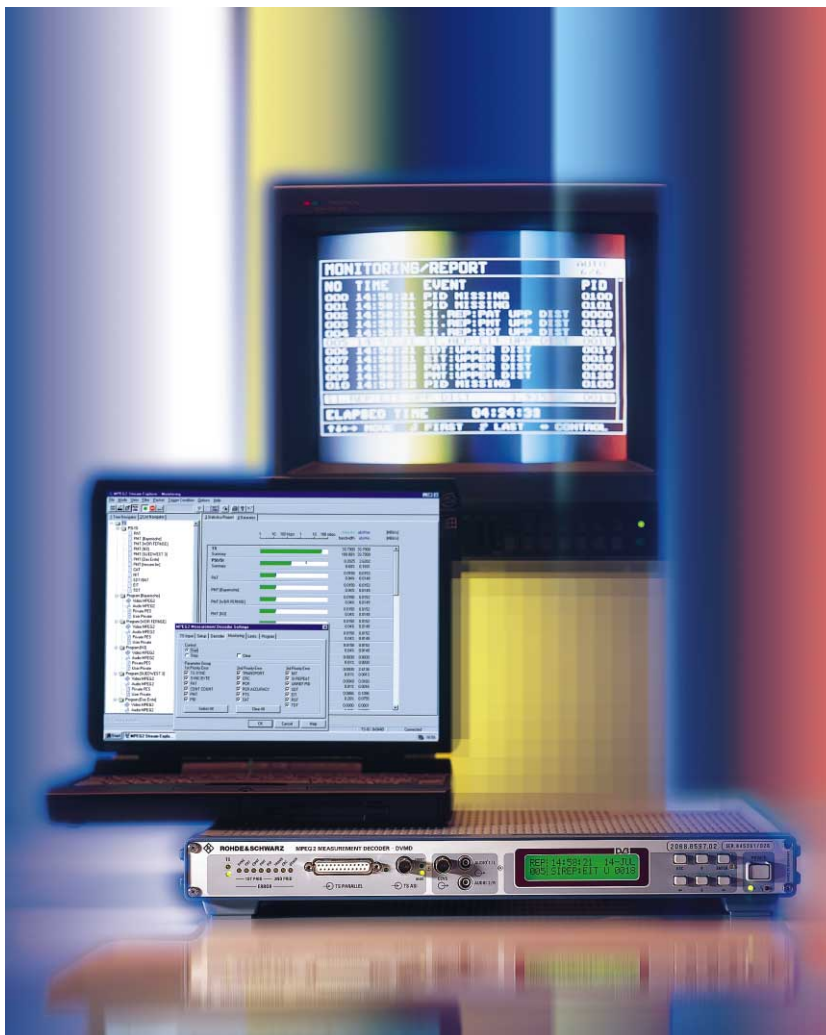

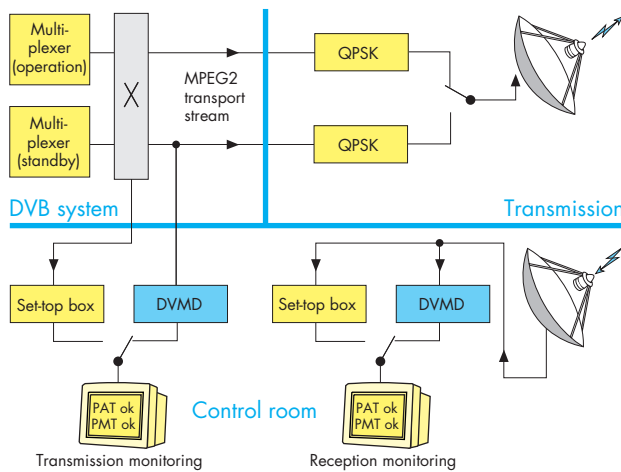

FIG 2
Block diagram of monitoring concept using two MPEG2 Measurement Decoders DVMD

mine whether they are caused by the satellite, by poor reception or by the multiplexer itself, which may transmit signals already errored.

Results after four months

Within the first 24 hours DVMD had signalled numerous errors, and after further investigation two causes for the MPEG2 errors could be tracked down in the DVB systems and eliminated by the supplier through parameter modifications. The causes of sporadic errors were extremely difficult to trace however. In these cases in-depth analyses are required for troubleshooting.

The **error display of DVMD** is clear and convenient. You merely select the parameter in question to find the error details. However, it is necessary to know exactly to what the error (eg Upper Dist) and PID (packet identification) of the errored element refer. For operation the PID number is sufficient since staff have a list of all important PIDs used in the programs. With the aid of DVMD, SRG-SSR detected errors in the broadcast programs. But most set-top boxes received these programs without major problems, except in one case where interruptions were heard. DVMD indicated that the PCRs (program clock references) were out of tolerance (Upper Dist). The PIDs were

determined and the programs were found to be really impaired. To detect the origin of the error, a more in-depth analysis was again necessary by the system supplier, who is also responsible for eliminating the problem.

Another major benefit of DVMD is its **decoder**. This makes it easy to determine the components of the service in question. Each component is displayed with its PID, data rate as well as the PID of the entitlement control message (ECM) that scrambles it, which facilitates error detection. DVMD has no decoder for the major conditional access systems, so it cannot be used as a set-top box, since all scrambled programs are invisible, meaning that a set-top box is necessary for monitoring.

Summary

DVMD does a very good job during operation as a detector of errors – or rather anomalies – in the MPEG2 program. In case of anomalies it detects the error and specifies the type and service or component impaired. The operator is thus in a position to assess whether he himself or only the supplier is able to eliminate the error in the system. During operation it is impossible to call in a technician if sporadic errors (duration <1 second) occur. He would have to spend the whole day

in front of DVMD to analyze errors of uncertain origin. To keep operating costs reasonable, a technician may only be called in case of a real alarm. At SRG-SSR alarm messages are output by a central system to which DVMD will also be connected and that will signal all errors lasting more than one minute (eg if a teletext PID fails).

SRG-SSR's objective is to ensure that all systems multiplexing its six television programs and the six radio programs of Radio Suisse International can be operated with a minimum of maintenance and repair. In view of the complexity of the systems, this will only be possible with the right working concept, and DVMD is an important part of it.

Damien Corti (SRG-SSR General Management, Engineering & Information Technology)

REFERENCES

- [1] Grunwald, S.: Analysis of compressed MPEG2 data stream for digital TV. News from Rohde & Schwarz (1997) No. 155, pp 22–23
- [2] Fischbacher, M.; Weigold, H.: MPEG2 Generator DVG and MPEG2 Measurement Decoder DVMD – Test equipment for digital TV in line with MPEG2. News from Rohde & Schwarz (1996) No. 152, pp 20–23