

Signal Analyzer R&S®FSQ / Spectrum Analyzer R&S®FSU

Measuring spurious emissions

By virtue of their sensitivity and excellent modulation capabilities, the R&S®FSU and R&S®FSQ (FIG 1) analyzer families are ideally suited for measuring spurious emissions. The new Spurious Emissions application for these instruments provides flexible device configuration and high measurement speed as well as straightforward evaluation of results. With up to 100 001 points per measurement, the analyzers do not miss a single spurious signal, even with large frequency ranges.

Configuring the measurement

Measuring spurious emissions is very important with nearly all devices under test that transmit RF power. The reason is that they usually must comply with frequency-dependent limits so that they do not interfere with other radio services or transmit unwanted signals in the case of security-relevant applications.

The R&S®FSU and R&S®FSQ analyzers support the measurement of spurious emissions with a new user-friendly application. For configuring the measurement, they provide up to 20 frequency ranges for which all relevant test parameters can be customized (FIG 2):

- ◆ Frequency range
- ◆ Level settings
- ◆ Bandwidths and sweep time
- ◆ Detector
- ◆ Number of measurement points
- ◆ Transducer

Measuring and evaluating

After a measurement has been configured and the suitable limit line switched on, one keystroke is all it takes to automatically run the measurement sequentially over the defined subranges. Of course, it is also possible to automatically stop the measurement at the end of a range, for example to switch the signal path. The measurement can also be stopped and resumed by remote control. At the end of the measurement, the analyzer displays all the ranges simultaneously on the monitor (FIG 3).

A single keystroke is all it takes to perform the numeric evaluation. With the PEAK LIST function, the analyzer marks all limit violations (FIG 3) and transfers them to a list. A safety margin can be added to the limit line and peak search, permitting additional analyses with respect to existing margins from the limits. For a quick overview, you can

Another article in this issue features the Signal Analyzer R&S®FSQ: "EVM measurements on ZigBee signals" on page 25.



FIG 1 The Signal Analyzer R&S®FSQ.

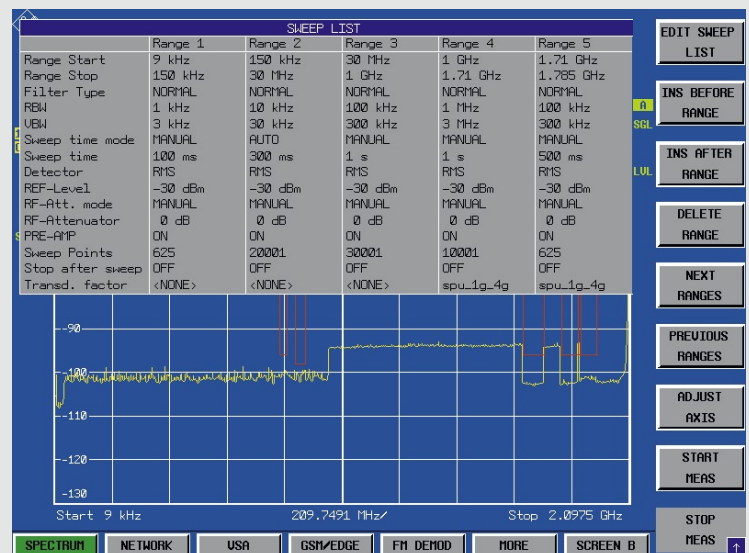

FIG 2 Configuration table for measuring spurious emissions.

choose between sorting the evaluation by frequency or by margin from the limit line (FIG 4).

Measurement accuracy

The factors that influence the measurement accuracy of the analyzers are explained in detail in [1].

RMS detector

With 30001 sweep points and 1 MHz resolution bandwidth, a frequency range of up to 7 GHz can be measured, without the error value of the RMS detector exceeding 0.2 dB. If requirements are more stringent, the frequency range is simply divided into multiple sweep ranges. A total of 100001 measurement points across all frequency ranges is allowed.

Modulation

Optimal modulation of the analyzer minimizes measurement errors and ensures a maximum dynamic range. The optimal reference level adapted to the DUT is therefore available in the sweep list for

Test setup used in the example

A 3GPP base station sends a multicarrier signal at the frequencies 2110 MHz and 2115 MHz. Spurious emissions are checked in accordance with category B, band I, wide-area base stations with coexisting GSM 900 network [2].

The 10 dB power attenuator is used as a broadband load for the base station. The level offset setting of 10 dB takes this into account. The bandstop filter used attenuates the carrier signals of the base station by at least 60 dB, allowing the reference level to be lowered without overloading the analyzer.

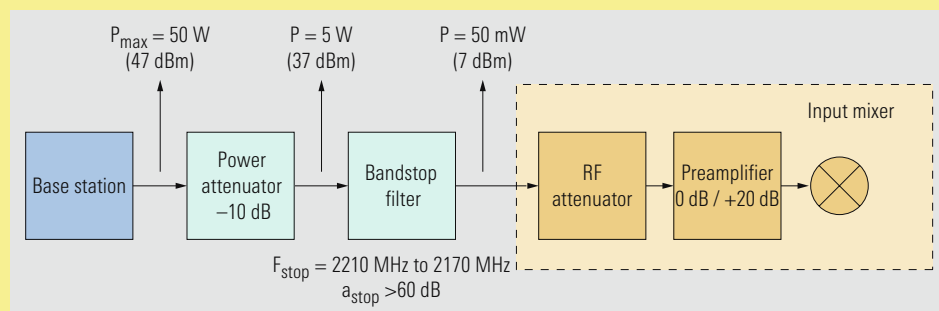

FIG 5 Test setup.

each frequency range. In addition, with measurements that extend into the GHz range, the frequency response of the external circuitry (e.g. cables or filters)

must be taken into account. For this purpose, the R&S®FSU and R&S®FSQ analyzers provide a separate transducer for each range for correcting the frequency

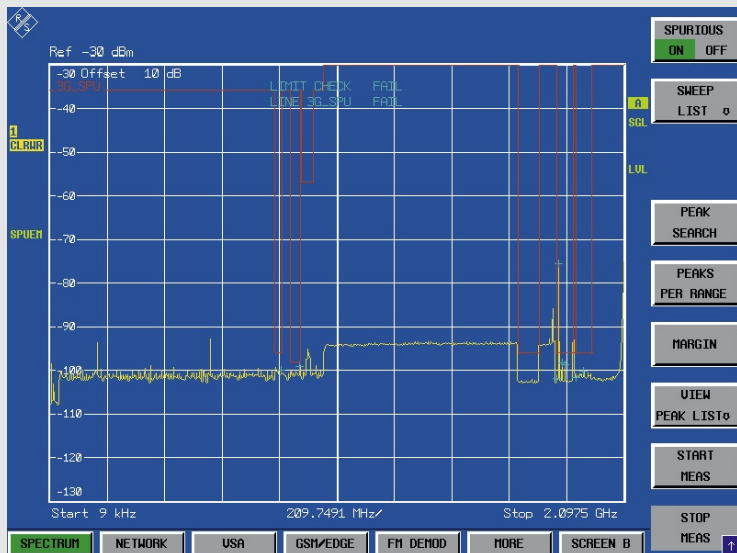

FIG 3 Measurement in the frequency range from 9 kHz to 2.0975 GHz. Red: limit line.

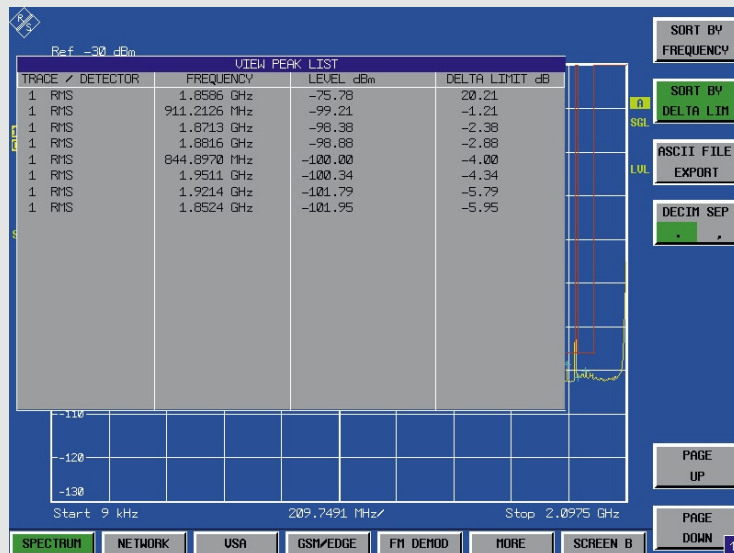

FIG 4 List of limit or margin violations, sorted by margin from the limit line.

- ▶ response of the external circuitry. The analyzers can now generate the data record necessary for this.

Equipped with the optional tracking generator (R&S®FSU-B9) up to 3.5 GHz or external generator control (R&S®FSP-B10), the analyzers can measure the frequency response in the NETWORK operating mode (FIG 6). With the SAVE AS TRD FACTOR function, they then convert the data record into a transducer that is subsequently used to compensate the frequency response error (FIG 7). The standardizing measurement (SOURCE CAL), which must be performed beforehand, eliminates virtually all level errors of the signal or tracking generator and of the analyzer, which means that only matching errors contribute to the measurement uncertainty.

A separate transducer can be assigned to each range of the sweep list, making a total of 12500 reference values possible for correcting the frequency response and thus allowing the residual error of the frequency response to be reduced to a minimum.

Summary

With the new Spurious Emissions application, the Spectrum Analyzer R&S®FSU and the Signal Analyzer R&S®FSQ offer a user-friendly and time-saving function for measuring spurious emissions. In combination with their low displayed average noise level and outstanding dynamic range, the analyzers are the first choice for this task.

The Spurious Emissions application is available as part of the basic software package for the R&S®FSU as of version 3.51 and for the R&S®FSQ as of version 3.55.

Richard Eßbaumer

More information, data sheets and the Application Note 1E45 at www.rohde-schwarz.com (search terms: FSU / FSQ / 1E45)



Application Note 1E45

REFERENCES

- [1] Spurious Emission Measurement on 3GPP Base Station Transmitters. Application Note 1E45 from Rohde & Schwarz
- [2] Technical Specification TS 25.141 V6.2.0, 3rd Generation Partnership Project (3GPP) Technical Specification Group, Radio Access Network, Base Station (BS) conformance testing (FDD) (Release 6)

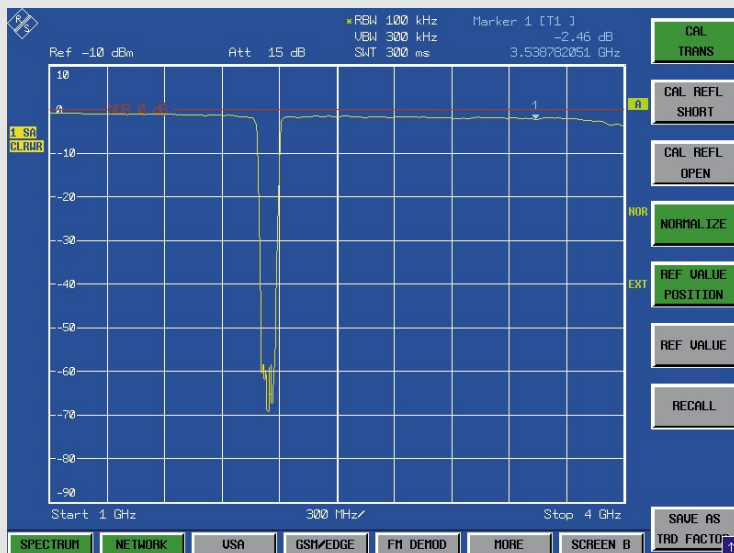

FIG 6 Measured frequency response of the notch filter used for carrier suppression.



FIG 7 Transducer automatically generated with SAVE AS TRD FACTOR.