



44 106

Vector Signal Generator R&S®SMU 200A

Complex signal scenarios at almost no effort

The high-end Vector Signal Generator

R&S®SMU 200A can house two complete generators with digital modulation capability in a single instrument [1]. This design not only saves 50% in space but also enables you to use applications that have previously either not been possible at all or only at high cost and effort.

Fast, two-path solution

A fully two-path R&S®SMU (i.e. with two baseband generators and two RF paths, FIG 1a) instead of two separate generators offers significant advantages. A classic application is the testing of receivers by superimposing an interfering signal. One path of the R&S®SMU generates the useful signal, the other the interferer. You can thus carry out tests on 3GPP base stations in accordance with TS25.141, for example, using both unmodulated and QPSK-modulated interferers. Also, the addition of noise (AWGN) is possible in both paths [2].

A high-end generator like the R&S®SMU, however, enables you to use measurement methods far beyond such standard scenarios. Every R&S®SMU baseband generator contains a powerful arbitrary waveform generator (ARB) which is fully supported by Simulation Software R&S WinIQSIM™. You can even

use multicarrier signals as interferers. For example, the receiver of a 3GPP mobile station can be tested during high network activity (i.e. the base station is transmitting on adjacent carrier frequencies simultaneously). A further application is the simultaneous simulation of different mobile radio standards, e.g. one path generates a 3GPP signal while the other generates a GSM carrier.

You can also route two baseband generators of an R&S®SMU to one RF path (FIG 1b). Their signals can be digitally added including power and frequency offset. The generator thus produces extremely complex signal scenarios that are highly similar to real conditions.

One scenario currently of great importance is the coexistence of different data transmission systems such as WLAN 802.11 or *Bluetooth*®*. Like WLAN 802.11 b and g, *Bluetooth*® uses the 2.4 GHz ISM band. Thus, if a WLAN

* The Bluetooth word mark and logos are owned by the Bluetooth SIG, Inc. and any use of such marks by Rohde & Schwarz is under license.

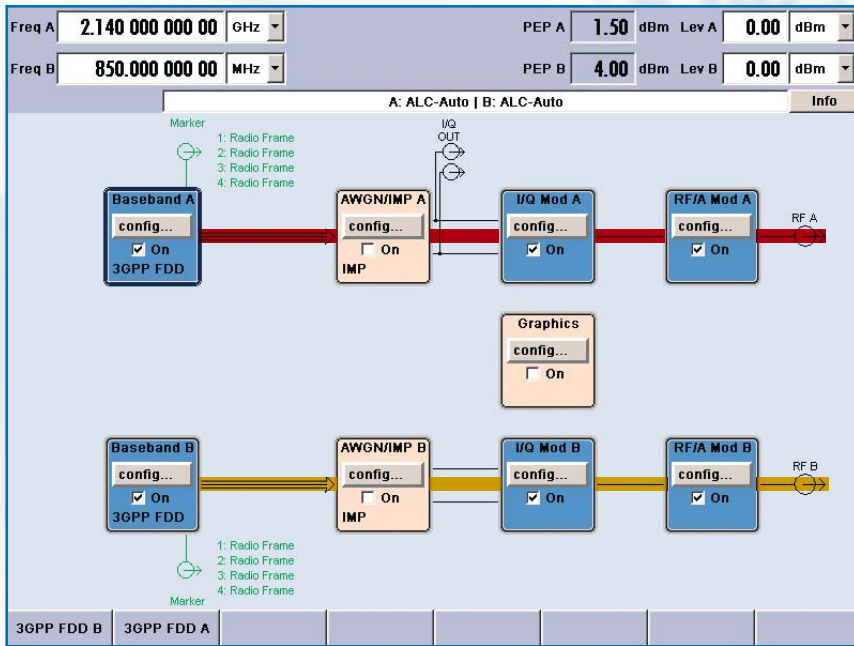

The two basic configurations of the two-path R&S[®]SMU:

FIG 1a

The R&S[®]SMU is a fully two-path vector signal generator, i.e. it has two baseband generators and two RF paths (two signal generators in one instrument). This is the ideal configuration if you want to use two paths independently of each other. This is also the optimum configuration for many receiver tests in which the useful signal and the interfering signal greatly differ in power and frequency offset (e.g. out-of-band blocking).

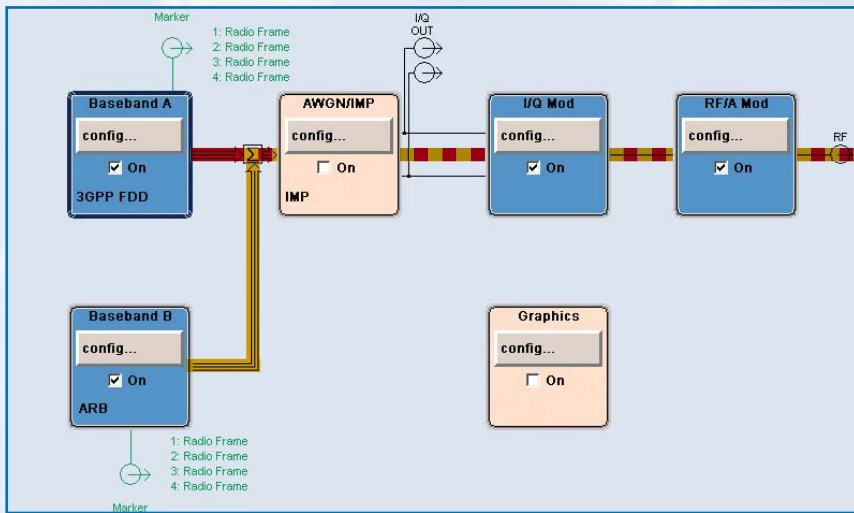

FIG 1b

You can also route two baseband generators to one RF path to generate very complex signals on one carrier frequency. In this case, no second RF path is required, as shown in the figure. If a second path is available however, you would even be able to generate another (unmodulated) signal.

FIG 2

With a two-path R&S[®]SMU, you can test the receiver quality of a WLAN card if a *Bluetooth* network is active in the same environment. In this case, a signal scenario like that shown in the time / frequency diagram will be generated. Baseband A generates the *Bluetooth* signal including the frequency hops (here, one *Bluetooth* master [yellow bar] and one *Bluetooth* slave [red bar]). Baseband B generates a WLAN signal at 2462 MHz (indicated by the light blue area).



- ▶ receiver is implemented in an environment in which a *Bluetooth* network is active, the receiver must be tested to ensure that it functions properly (and vice versa). An R&S®SMU with two baseband generators can provide the test signal needed (WLAN useful signal with *Bluetooth* interferer) (FIG 2).

Bluetooth operates with frequency hopping in a band that is 79 MHz in width. The channel spacing is 1 MHz. Since the R&S®SMU is able to generate digitally modulated signals that are up to 80 MHz in width with the internal baseband, the entire *Bluetooth* band, including the frequency hops, can be simulated with an R&S®SMU baseband generator. The signal is then calculated with R&S WinIQSIM™ and played in the ARB of the baseband generator. The second baseband generator produces the 802.11 useful signal for the receiver test.

Although you could certainly generate a combined WLAN *Bluetooth* signal with one ARB, using the two baseband generators of the R&S®SM offers several advantages. For one, it keeps the large amount of data involved from presenting problems. Specifically, receiver tests usually require frame sequences that are 1000 frames or more in length. If these long sequences are combined with a background signal that is 79 MHz in width, the resulting waveform files are so large that many PCs cannot handle them. It would therefore be better to process the two signal components separately and subsequently add them together in realtime in the baseband section of the R&S®SMU.

The greatest benefit of the R&S®SMU solution, however, is being able to define the power and frequency offset in realtime. Thus, the S/N ratio can be varied without having to recalculate the signal each time. You can also repeat the tests for different WLAN carrier frequencies without any recalculation being required.

The comprehensive trigger and synchronization capabilities of the R&S®SMU baseband section offer further applications. For example, one baseband generator can be triggered by the other and the trigger time can be varied in realtime. The R&S®SMU can thus simulate timing errors in GSM systems, for example. This involves baseband A generating the master frame and baseband B a single timeslot (FIG 3). If B is now triggered by A and this trigger is slightly delayed, the timeslot generated by B is slightly delayed with respect to the frame time grid. This is another realistic scenario for receiver tests.

These are just a few examples of the many applications that are possible with the two-path Vector Signal Generator R&S®SMU. Additional applications are described in [3]. An R&S®SMU with two paths thus not only contains two complete signal generators but can also generate complex signal scenarios that have previously not been possible at all or only at a high cost and effort.

Dr René Desquiotz

More information and data sheet at www.rohde-schwarz.com
(search term: SMU)

REFERENCES

- [1] Vector Signal Generator R&S®SMU 200A: The art of signal generation. News from Rohde & Schwarz (2003) No. 180, pp 21–27
- [2] Vector Signal Generator R&S®SMU 200A: Noise – an annoyance? Not with the new noise option. News from Rohde & Schwarz (2004) No. 182, pp 38–39
- [3] New Dimensions in Signal Generation with the R&S®SMU 200A. Rohde & Schwarz Application Note 1GP50 (to be published in autumn 2004).

FIG 3
Simulation of a GSM timeslot with incorrect timing. Baseband A generates the master frame and triggers baseband B, which provides the timeslot to be analyzed. When the trigger is delayed, this timeslot can be shifted with respect to the time axis of the master frame.

