

Version  
02.00December  
2004

## Baseband Fading Simulator R&S® ABFS

Saving costs through real-world fading tests

- ◆ Two fading channels  
(four with option R&S® ABFS-B2)
- ◆ 12 propagation paths  
(24 with option R&S® ABFS-B2)
- ◆ Dynamic fading for WCDMA 3GPP  
(with options R&S® ABFS-B49 and  
R&S® ABFS-B50)
- ◆ Universal use in research, develop-  
ment and production
- ◆ Simulation of present and future  
communications systems owing to  
flexible concept
- ◆ Receiver tests at I/Q level together  
with a baseband source
- ◆ Ease of operation
- ◆ High reliability



**ROHDE & SCHWARZ**

The characteristics of a radio channel can strongly impair signal transmission between a transmitter and in particular a moving receiver.

The Baseband Fading Simulator R&S® ABFS generates signals that simulate real receive conditions in mobile applications. Thus, the response of receivers under real-world conditions can already be checked during development and QM acceptance testing. The simulation of fading signals at baseband level reduces costs.

### Advantages of fading simulation in the baseband

Conventional fading simulators normally convert the signal of the radio channel to the IF, perform fading and then reconvert the signal to its RF frequency. It is, however, less costly to loop in the simulator prior to the first conversion to the carrier frequency, i.e. to simulate at baseband level (I and Q) and then convert to the correct frequency in the test system (see Fig. 3). Signals will therefore not be impaired by the effects of multiple conversion. This baseband fading simulation makes upgrading to new networks or standards easy.

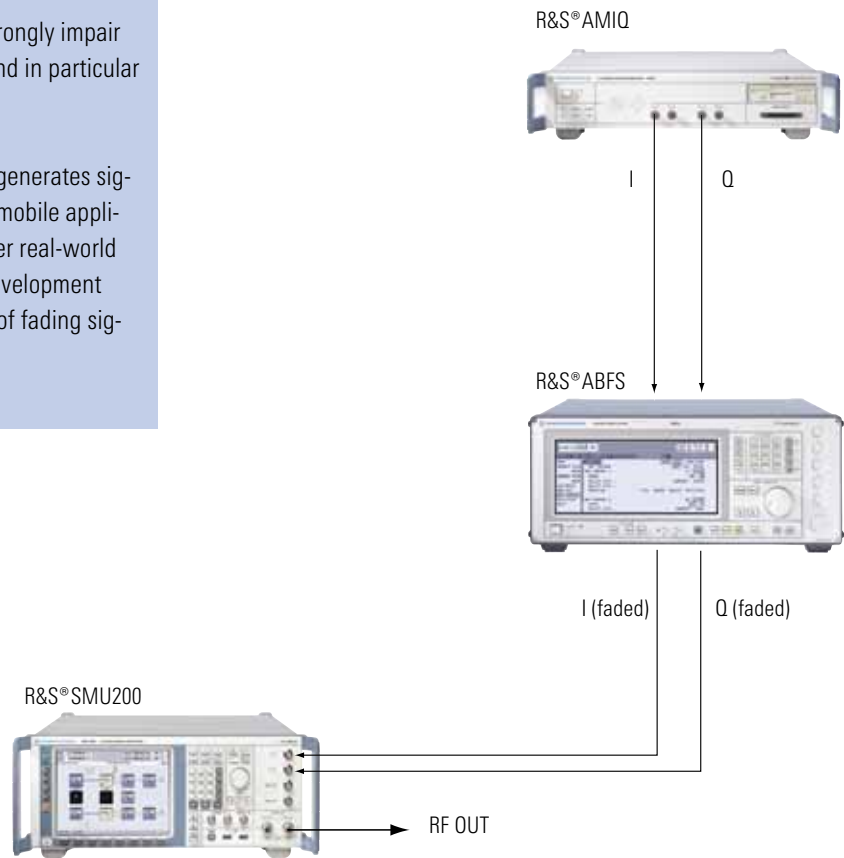
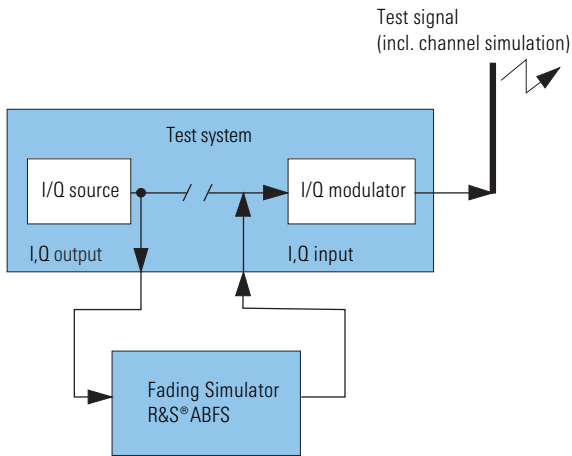

Fig. 1: Fading of a baseband signal from the R&S® AMIQ with the Fading Simulator R&S® ABFS



Fig. 2: The R&S® CMU 200 with option R&S® CMU-B17 in combination with the Fading Simulator R&S® ABFS for receiver tests under fading conditions



**Fig. 3: Fading simulation in the baseband**

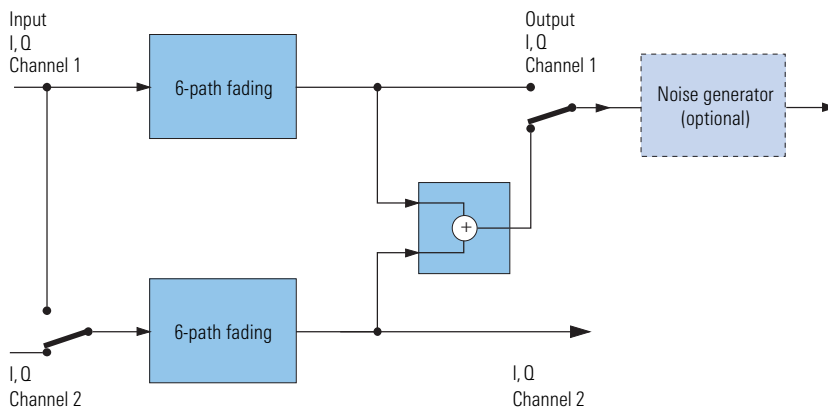

**Fig. 4: Interconnections of the R&S® ABFS**

### Fit for the future

The Baseband Fading Simulator R&S® ABFS is suitable for universal mobile radio applications in research, development and production.

It comprises all scenarios and statistical models for simulating sporadic fading as specified in the test regulations of mobile radio standards (e.g. GSM, 3GPP WCDMA or CDMA2000®).

The flexible concept of the R&S® ABFS allows the simulation of radio channels of existing and future communications systems (e.g. mobile radio, broadcasting, flight telephone, WLL, or WLAN systems).

The R&S® ABFS can also simulate frequency hopping systems. The R&S® ABFS is fast enough to follow the frequency hopping of a test system, for example within a frame of 4.616 ms (GSM frame time).

Furthermore, an offset voltage for each I and Q input or output can be entered to compensate for external DC offset voltages.

Together with a baseband source (e.g. the I/Q Modulation Generator R&S® AMIQ, see Fig. 1), receiver tests can be performed at the I/Q level even if the corresponding RF link is not available. During the development of receivers or correction circuits in the receiver (e.g. equalizer), the effects of fading can thus be checked at a very early stage.

The R&S® CMU 200 with the option R&S® CMU-B17 in combination with the Fading Simulator R&S® ABFS can also be used for receiver tests under fading conditions (Fig. 2).

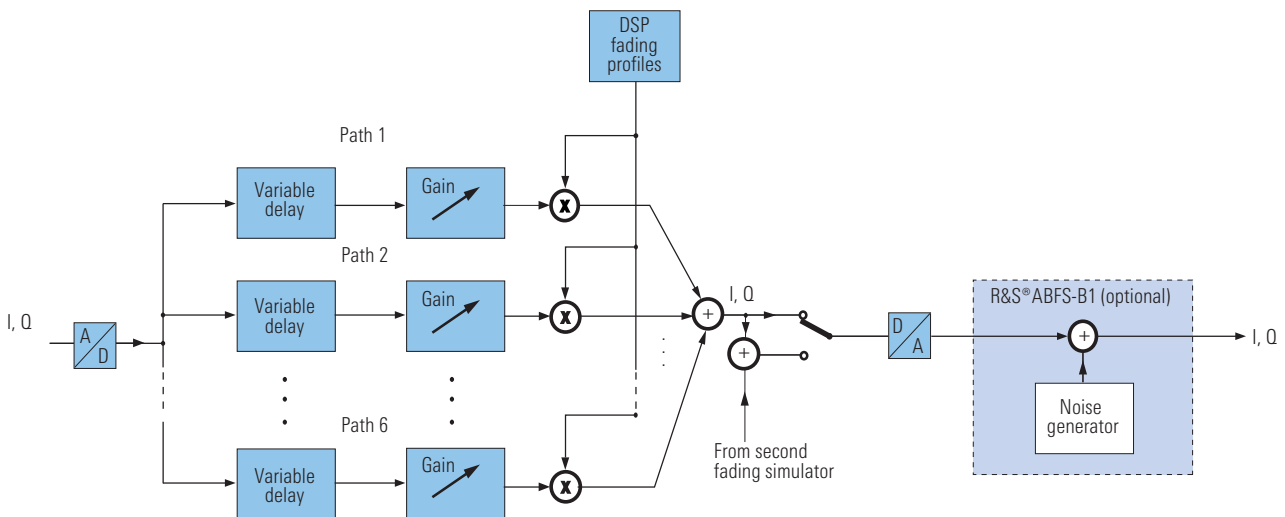

**Fig. 5: Diagram of fading simulator**

The basic model of the R&S® ABFS comes with two independent channels for six-path fading. The two channels can be interconnected as follows (see Fig. 4):

- ◆ Distribution of an input to two outputs (e.g. with different fading profiles). This feature makes it possible to simulate the signal of two antennas with different characteristics or frequency diversity methods
- ◆ Simulation of two channels with individual profiles and addition at the output. Cell change or superposition of interferers can be tested with this configuration
- ◆ Coupling of two channels so that a channel with 12 propagation paths is obtained (Fig. 5 provides a more detailed insight into the operation of the fading simulator)

## High versatility through options

The Noise Generator R&S® ABFS-B1 adds a noise source to the output of the first channel (see Fig. 4) so that noise can be simulated in the frequency band used. The noise generator can be switched on or off irrespective of the operating modes of the basic version.

The optional Second Fading Simulator R&S® ABFS-B2 offers two extra channels with the same characteristics in addition to the two channels of the basic model.

The optional Second Noise Generator R&S® ABFS-B3 provides an additional noise source for a further output. This second noise generator is either assigned to the second channel of the basic R&S® ABFS (with the first Noise Generator R&S® ABFS-B1 for the first channel) or to the first channel of the Second Fading Simulator R&S® ABFS-B2.

**Fig. 6: Typical Rayleigh fading profile**

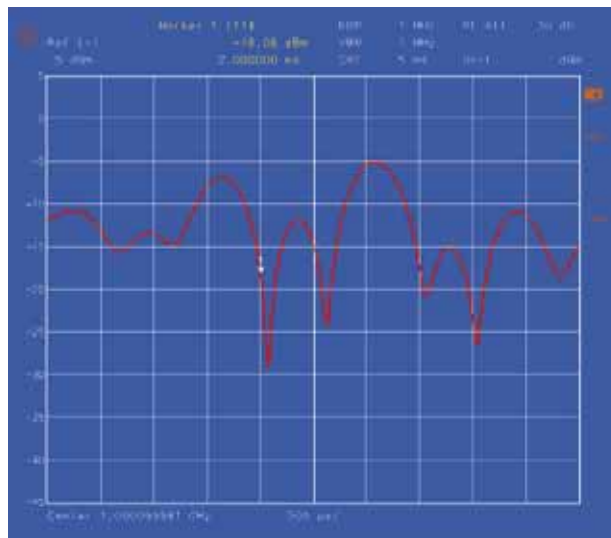

**Fig. 7: Rayleigh fading (Doppler spectrum), generated at a speed of 180 km/h (RF = 1.8 GHz)**

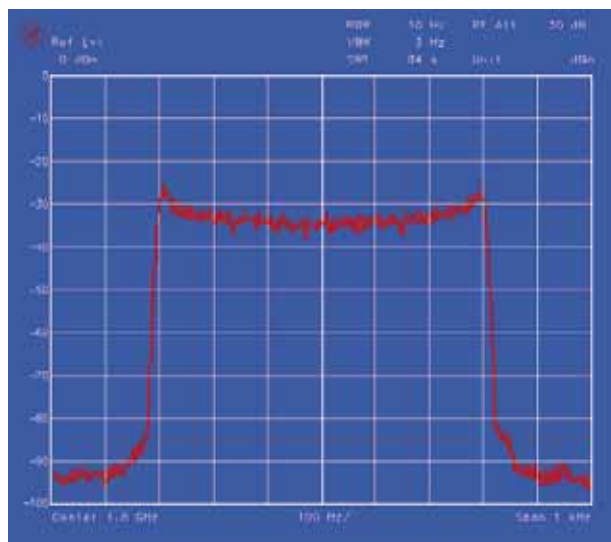

## Why fading tests?

Short-time signal fading, as caused by multipath propagation, strongly affects the error rate of the received signal due to the short symbol periods in digital mobile radio. Modern digital systems overcome these problems with the aid of appropriate error control coding methods as well as algorithms for delay equalization.

Interleaving is employed to overcome the problem of losing large parts of the messages. Resistance to fading is an essential quality criterion of digital mobile radio systems and means a considerable competitive advantage for the manufacturer.

Tests with real-world signals using fading simulators are a must to spot the weak points in new concepts at an early stage so that appropriate modifications can be made.

Fading profiles such as Rayleigh, Rician, pure Doppler, Lognormal or Suzuki can be assigned to each of the propagation paths irrespective of the selected circuit (see Fig. 4).

In addition to the fading profiles mentioned, the following parameters can be defined for each propagation path:

- ◆ Path attenuation
- ◆ Delay time
- ◆ Doppler frequency or speed between transmitter and receiver
- ◆ Coupling to another channel

Many fading models (e.g. GSM Rural Urban, Typical Urban) have already been programmed in the R&S® ABFS. The user can quickly recall these default settings and also modify the parameters.

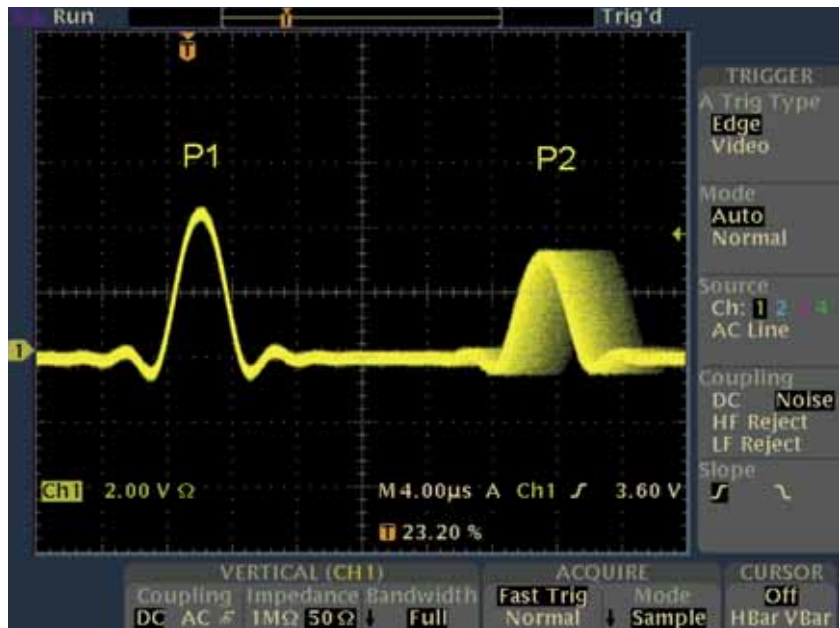

Fig. 8: Baseband signal with ASK modulation which was subjected to moving propagation

### Enhanced fading functions for 3GPP WCDMA

The R&S® ABFS-B49 option extends the functionality of the Baseband Fading Simulator R&S® ABFS to include 3GPP WCDMA channel simulation. It adds three new modes to the fading simulator so that all scenarios defined in 3GPP Release 99 can be simulated:

- ◆ In fine delay mode, the fading simulator resolution is increased to 1 ns with up to four paths being available
- ◆ In moving delay mode, two paths are simulated: the delay for one path remains constant, whereas the delay for the other path varies continuously
- ◆ In birth/death mode, there are two paths where the delay changes in steps in accordance with the 3GPP channel model

The option R&S® ABFS-B50 enables the enhanced fading functions for 3GPP WCDMA for the second fading simulator.



Fig. 9: The R&S® ABFS is included in the RF Precompliance Test System R&S® TS8955 (for GSM and WCDMA)

## Specifications

I/Q inputs and outputs	
Impedance	50 Ω
Voltage for full-scale level	$\sqrt{U_i^2 + U_o^2} = 0.5 \text{ V}$
Residual DC voltage at output	<2 mV, fine tuning by software
Insertion loss of basic unit	0.3 dB

Fading simulation	
Number of propagation paths and fading channels	
Basic model	1 channel with 12 paths or 2 channels with 6 paths each
With option R&S®ABFS-B2	2 channels with 12 paths each or 4 channels with 6 paths each
Insertion loss between input and output at 0 dB path attenuation	min. 9 dB
Frequency response	
Up to 5 MHz offset from carrier frequency (corresponding to 10 MHz system bandwidth)	+0.1 dB to -0.6 dB
Path attenuation	
Range	0 dB to 50 dB
Resolution	0.1 dB
Error in range 0 dB to 20 dB	<0.3 dB
Path delay	
Range	0 s to 1600 μs
Resolution	50 ns
Error	<5 ns
Doppler shift	
Frequency range	0.1 Hz to 1600 Hz
Speed range	$v_{\min} = \frac{0.03 \times 10^9 \text{ m}}{f_{\text{RF}} \text{ s}^2}$ $v_{\max} = \frac{479 \times 10^9 \text{ m}}{f_{\text{RF}} \text{ s}^2}$ <p>For example at <math>f_{\text{RF}} = 1 \text{ GHz}</math>:  <math>v_{\min} = 0.1 \text{ km/h}</math>, <math>v_{\max} = 1724 \text{ km/h}</math></p>
Resolution	0.1 km/h, $\frac{\text{m}}{\text{s}}$ , mph
Error	<0.13 %
Rayleigh fading	
Pseudo noise interval	>372 h
Deviation from theoretical CPDF <sup>1</sup> at $P_{\text{avg}} = 0 \text{ dB}$	
In range -20 dB to +10 dB	<1 dB, typ. <0.3 dB
In range -30 dB to -20 dB	<2 dB, typ. <0.3 dB
Rice fading	
Power ratio <sup>2</sup>	
Range	-30 dB to +30 dB
Resolution	0.1 dB

Frequency ratio	
Range	-1 to +1
Resolution	0.05
Lognormal fading, Suzuki fading	
Standard deviation	
Range	0 dB to 12 dB
Resolution	1 dB
Local constant	$I_{\min}$ to 200 m, $I_{\min} = \frac{12 \times 10^9 \text{ m}}{f_{\text{RF}} \text{ s}}$
Correlation	paths 1 to 6 with paths 7 to 12 of a channel (A or B)
Range for magnitude	0 % to 100 %
Resolution	5 %
Range for phase	0 ° to 360 °
Resolution	1 °
RF setting	setting of the RF results in an automatic calculation and display of the Doppler frequency in line with the set motion speed <sup>3</sup>
Range (for each fading channel)	5 MHz to 8.5 GHz
Frequency hopping mode	RF can be stored in a list and quickly set via a serial interface
Interface	RS-232-C, 1 byte with start and stop bit
Addressing of frequency list	8 bit or 16 bit as address for each fading channel
Setting time after frequency change during Rayleigh fading	<3.5 ms

Noise generator with option R&S®ABFS-B1 or R&S®ABFS-B3	
Amplitude distribution	Gaussian, statistically independent for I and Q
Crest factor	14 dB
Noise power level in relation to full-scale level	
Range	-17 dBfs to -50 dBfs
Resolution	0.05 dB
Error	<0.3 dB
Output level at full-scale level (AC)	$\sqrt{U_i^2 + U_o^2} = 0.5 \text{ V}$ (= 4 dBm)
Insertion loss between input and output	0 dB, 6 dB, 12 dB to 42 dB
Output spectrum	white noise
Bandwidth	depending on set system bandwidth
Frequency response up to 0.7 × system bandwidth (max. 5 MHz)	<0.5 dB
RF system bandwidth <sup>4</sup>	bandwidth determining noise power
Setting range	10 kHz to 10 MHz
Resolution	1 %
Memory for device settings	
Storable settings	50
Frequency response	-0.2 dB to -0.6 dB

<sup>1</sup> CPDF: cumulative probability distribution function.

<sup>2</sup> Ratio between discrete and distributed component.

<sup>3</sup> The phase differences between paths caused by different settings of path delay are taken into account when the RF is modified. This applies to frequency hopping mode only.

<sup>4</sup> 0.5 × system bandwidth is used for baseband.

### Enhanced fading functions for 3GPP WCDMA with options R&S® ABFS-B49/-B50

The enhanced fading functions for 3GPP WCDMA are available for the R&S® ABFS standard fading simulator (option R&S® ABFS-B49) and with the R&S® ABFS-B50 also for the second fading simulator (option R&S® ABFS-B2).

Modes	standard fading, fine delay, birth/death
Setting time after RF frequency change	6 ms
Fine delay mode	
RF bandwidth	4.8 MHz
Number of paths	4
Profiles	Rayleigh, pure Doppler
Delay	25 ns to 1637 µs
Delay resolution	1 ns
Moving delay mode	
RF bandwidth	4.8 MHz
Number of paths	2
Delay	
Path 1	0 s to 1000 µs (in 50 ns steps)
Path 2	$\text{delay path} \times \frac{\text{delay variation}_{\text{pk-peak}}}{2} \times \sin \frac{2 \times t}{\text{variation period}}$
Delay variation (peak-peak)	150 ns to 50 µs
Variation period	10 s to 500 s
Delay step size	<1 ns
Profiles	none
Birth/death mode	
Number of paths	2
Profiles	pure Doppler
Delay	5 µs to 1000 µs
Delay range (birth/death process)	-5 µs to +5 µs (not variable)
Delay grid	1 µs (not variable)
Hopping dwell	100 ms to 5 s

### Remote control

System	IEC 625 (IEEE 488)
Command set	SCPI 1993.0
Connector	Amphenol 24-pin
IEC/IEEE-bus address	0 to 30
Interface functions	SH1, AH1, T6, L4, SR1, RL1, PP1, DC1, DT1, C0

### General data

Power supply	90 V to 132 V (AC), 47 Hz to 440 Hz, 180 V to 265 V (AC), 47 Hz to 440 Hz, autoranging, max. 300 VA
Electromagnetic compatibility	meets EN 61000-6-3 and EN 61000-6-2
Environmental conditions	
Operating temperature range	0 °C to 45 °C, meets EN 60068-2-1, EN 60068-2-2
Storage temperature range	-40 °C to +70 °C
Climatic resistance	95% rel. humidity, cyclic test at +25 °C/+40 °C, meets EN 60068-2-3, EN 60068-2-30
Mechanical resistance	
Vibration, sinusoidal	5 Hz to 150 Hz, max. 2 g at 55 Hz, 55 Hz to 150 Hz, 0.5 g const., meets EN 60068-2-6
Vibration, random	10 Hz to 300 Hz, acceleration 1.2 g (rms)
Shock	40 g shock spectrum, meets EN 60068-2-27, MIL-STD-810D, MIL-T-28800D, class 3 and 5
Safety	meets EN 61010-1
Dimensions (W × H × D)	435 mm × 192 mm × 460 mm
Weight	20 kg when unit is fully equipped

### Ordering information

Baseband Fading Simulator	R&S® ABFS	1114.8506.02
<b>Accessories supplied</b>		
Power cable, operating manual		
<b>Options</b>		
Noise Generator	R&S® ABFS-B1	1115.0009.02
Second Fading Simulator	R&S® ABFS-B2	1115.0309.02
Second Noise Generator	R&S® ABFS-B3	1115.0609.02
Enhanced Fading Functions for 3GPP WCDMA	R&S® ABFS-B49	1115.0909.02
Enhanced Fading Functions for 3GPP WCDMA for second fading simulator (R&S® ABFS-B49 required)	R&S® ABFS-B50	1403.4007.02
<b>Recommended extras</b>		
19" Rack Adapter	R&S® ZZA-94	0396.4905.00
Service Kit	R&S® SM-Z3	1085.2500.02
Service Manual	R&S® ABFS	1114.8564.94

More information at  
[www.rohde-schwarz.com](http://www.rohde-schwarz.com)  
(search term: ABFS)



[www.rohde-schwarz.com](http://www.rohde-schwarz.com)

Europe: Tel. +49 1805 12 4242, e-mail: [customersupport@rohde-schwarz.com](mailto:customersupport@rohde-schwarz.com) · USA: Tel. +1 410-910-7988, e-mail: [customer.support@rsa.rohde-schwarz.com](mailto:customer.support@rsa.rohde-schwarz.com)  
Asia: Tel. +65 68463710, e-mail: [customer-service@rsg.rohde-schwarz.com](mailto:customer-service@rsg.rohde-schwarz.com)