



FIG 1 The most important components in the WCDMA Base Station Test Set R&S®FSMU-W are the Signal Analyzer R&S®FSQ (above) and the Vector Signal Generator R&S®SMU 200A.

44264/2

The WCDMA Base Station Test Set R&S®FSMU-W can handle all test cases specified in 3GPP TS25.141 (transmitter, receiver and performance tests). The most important components of the new test set are the two high-end instruments R&S®SMU200A and R&S®FSQ.

WCDMA Base Station Test Set R&S®FSMU-W

Quick and easy WCDMA base station testing

Preconfigured all-in-one solutions are in demand

Test specifications such as TS25.141 (base station conformance testing (FDD)) are a prerequisite in order for the 3GPP WCDMA standard to function properly worldwide and for equipment to be interoperable. Therefore, base station manufacturers must ensure that their equipment complies with these specifications. However, a number of obstacles have to be overcome:

- ◆ Compliance with extensive technical specifications must be achieved
- ◆ Complex test procedures must be taken into account
- ◆ Standardized test software must be developed

This means long periods of training and preparation for setting up test systems and can delay their market introduction. Therefore, the parties involved are not only buying individual measurement instruments – which naturally have to

meet the highest quality standards – but also expect preconfigured all-in-one solutions from test equipment suppliers.

Due to its flexible concept, the WCDMA Base Station Test Set R&S®FSMU-W does a good job of fulfilling these new requirements. It meets the highest quality standards and helps you to set up test systems quickly and to carry out acceptance tests by providing the following:

- ◆ Extensive application software with detailed descriptions
- ◆ Preconfigured test solutions with PC-based remote control
- ◆ Simplified programming due to an integrated wizard
- ◆ Measurement programs that can be modified in ANSI-C as required
- ◆ Options for expanded measurement procedures

All essential test cases fully preconfigured

The main components of the R&S®FSMU-W are the Signal Analyzer R&S®FSQ and the Vector Signal Generator R&S®SMU200A (FIG 1) as well as a PC-based remote-control software application. This preconfigured all-in-one solution enables you to carry out tests on 3GPP base stations in accordance with TS25.141 immediately. The customary and time-consuming integration of analyzers and signal generators into test procedures is no longer necessary.

FIG 2 shows an example of a test setup. The remote-control software performs the necessary settings on the generator and analyzer. The base station under test emits a trigger to start signal generation in the R&S®SMU200A and responds to the generator's reverse link signal by changing the power in the forward link. The R&S®FSQ measures and evaluates the change in power triggered by the generator.

Due to the expandability of the R&S®SMU200A, the test setup is much more compact than previous solutions. For the R&S®FSMU-W, the following options are available: second RF path, second baseband source and fading simulation. They enable you to run all test cases for transmitters and receivers specified in TS25.141. A detailed overview of the more than 30 test cases and the options they require are listed in the data sheet, which can be downloaded from the Internet.

Signal Analyzer R&S®FSQ

The high-end Signal Analyzer R&S®FSQ [1], which is available in three models up to 3.6 GHz, 8 GHz or 26.5 GHz, has a very wide dynamic range. Its convenient operation and well-organized measurement functions make combining test protocols quick and easy.

High sensitivity, low phase noise and high intermodulation suppression enable the R&S®FSQ to measure the adjacent channel leakage ratio (ACLR) of a 3GPP FDD signal with a dynamic range of up to 77 dB. Its intelligent signal processing improves this value to up to 85 dB and far exceeds the requirements in TS25.141; the influence of the instrument on the measurement results is therefore negligible.

The R&S®FSQ also offers excellent RF performance and flexible functions when measuring spurious emissions. The analyzer can divide the frequency sweep into as many as 20 different segments, and each segment can be set with different parameters – for example measurement bandwidth, reference level and the number of measurement points (up to 100001). Nevertheless, the entire measurement of spurious emissions is completed in less than one second. The results can be stored directly as an ASCII file and read out via the IEC/IEEE bus or a LAN.

Measurements in the spectral range alone are not sufficient for determining the characteristics of a WCDMA transmitter. Instead, an in-depth evaluation requires code domain analysis – for example, measuring the modulation accuracy or exact checking of the transmitter's power control. The R&S®FSQ can intercept and analyze up to 100 consecutive frames. It automatically detects the active channels for each of the 15 timeslots in one frame. Likewise, it automatically finds the QPSK and 16QAM modulation formats used with HSDPA. ▶

FIG 2 Test setup for test case 6.4.2 (power control steps).

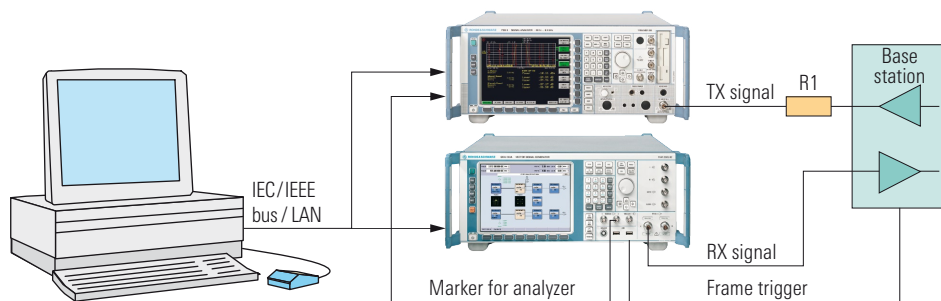

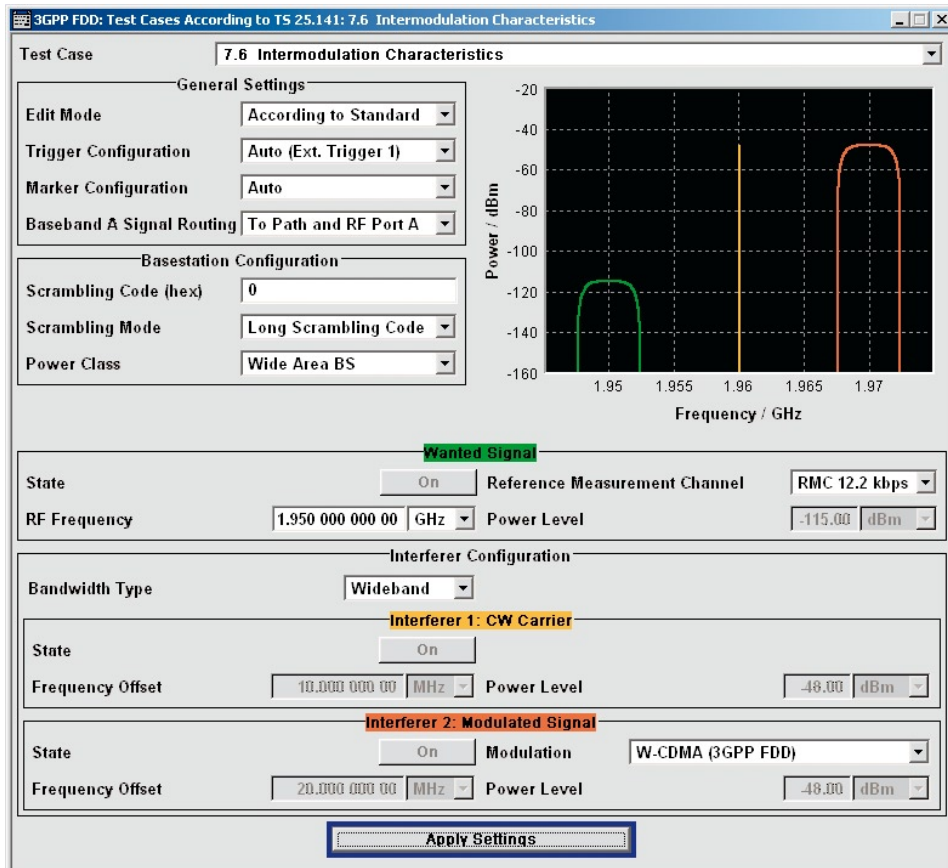

FIG 3 Wizard menu for test case 7.6 (intermodulation characteristics).

► Vector Signal Generator R&S®SMU200A

The Vector Signal Generator R&S®SMU200A [2] provides all test signals specified in TS25.141. The R&S®SMU200A meets the high requirements that development and production place on a state-of-the-art signal generator by providing outstanding RF characteristics (3GPP ACLR of typ. +70 dB, wideband noise of typ. -153 dBc) and unique features such as:

- ◆ Two independent signal paths, from the baseband generation (3GPP, HSDPA, etc) to the RF output
- ◆ Simulation of real radio propagation conditions (fading, AWGN, CW interferers)

A 3GPP test case wizard that can be started via the 3GPP menu provides a convenient means of operating the generator. The wizard makes all necessary settings, e.g. the signals and markers in the baseband, the injection of interferers, fading simulation, RF power and frequency. This convenient wizard frees you from having to set each and every parameter that is necessary for a test case.

As an example, FIG 3 shows the wizard's menu for test case 7.6 (intermodulation characteristics), which is divided into various sections.

The General Settings section is used to set signal generator parameters such as

edit mode, trigger and marker configuration, and signal routing, for example.

The next section is used to configure general base station parameters. The section in the bottom half of the screen contains settings specific to the test case. These settings primarily include frequency and level as well as wanted and unwanted signals to be generated. The graphs show the frequency and level of the signals generated by the R&S®SMU200A. In this test case, a base station is being tested to determine whether an unwanted 3GPP signal at 1.97 GHz together with an unwanted CW signal at 1.96 GHz (both have a relatively high transmit level of -48 dBm) impair the reception of a weak wanted signal of only -115 dBm on a reference measurement channel (RMC) at 1.95 GHz.

FIG 4 shows the signal flow in the R&S®SMU200A that is necessary for test case 7.6. Upon receiving an external trigger, baseband generator A starts a 3GPP RMC signal which is routed to RF output A as a wanted signal. At the same time, the lower baseband generator B generates an interference reverse link signal that is routed to RF output B as an unwanted signal together with an unwanted CW signal generated in the AWGN/IMP B module. That means that a single R&S®SMU200A can simultaneously generate three baseband signals.

A comparison of FIG 3 and FIG 4 makes the main advantage of the test case wizard clear: While the wizard menu in FIG 3 requires only a few settings (power class, bandwidth type, RF frequency), the graphical user interface of the R&S®SMU200A (FIG 4) requires that a number of modules be switched on and off to configure the generator correctly for the test specification.

Despite its convenience, the wizard is highly flexible. Experienced users can still depart from the specifications in

TS25.141 and take full advantage of the generator's capabilities. For example, the edit mode lets you choose whether to strictly comply with the recommendations in TS25.141 or to determine the performance limits of a base station under more stringent conditions (e. g. under an extremely reduced level of the wanted signal). You can also modify signal generation after you run the test case. In test case 7.6 in FIG 3, for example, you could activate the generator in the AWGN/IMP A module and thus superimpose additional interference on the wanted signal.

Flexible software control

Like the wizard, the PC-based software control that is included offers broad flexibility. It can generate ready-to-run test configurations, but also helps to quickly set up customized measurement procedures. To make this possible, all modules needed for test cases are written in ANSI-C. The modules provide elementary functions – e. g. instrument initialization/reset and writing/reading via the remote-control bus – as well as program examples which can serve as a basis for complex test sequences. A comprehensive operating manual describes the test procedures in detail and provides numerous tips and tricks.

Summary

Mobile radio manufacturers must comply with test specifications to be successful on the market. The struggle for every tenth of a dB requires highly accurate signal generation and precise analysis functions in the measuring instruments. The WCDMA Base Station Test Set R&S®FSMU-W, which includes the two high-end instruments R&S®SMU200A and R&S®FSQ, is an excellent tool for testing base stations in accordance with TS25.141.

Dr Karlheinz Pensel; Johan Nilsson

FIG 4 Configuration of the R&S®SMU200A for the intermodulation characteristics test in accordance with test case 7.6.

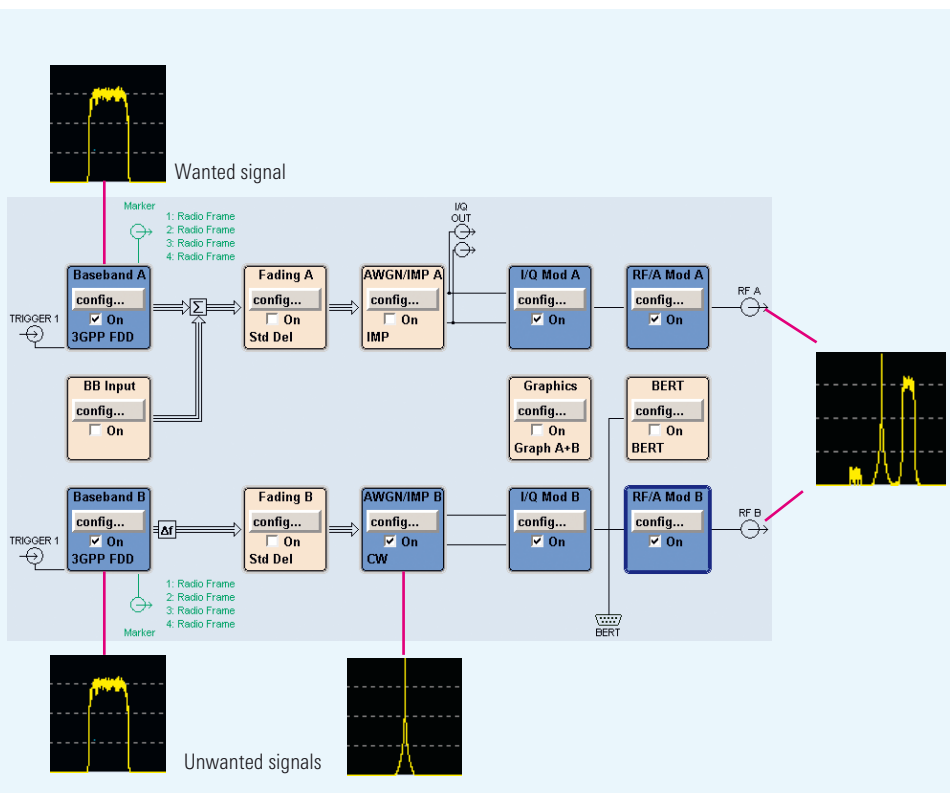

More information, data sheets and application notes at www.rohde-schwarz.com (search terms: FSMU-W, SMU200A, FSQ)



Brochure
R&S®FSMU-W

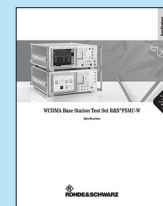

Specifications
R&S®FSMU-W

REFERENCES

- [1] Spectrum and signal analyzers for every requirement – an overview. News from Rohde & Schwarz (2004) No. 182, pp 30–36
- [2] Vector Signal Generator R&S®SMU200A: The art of signal generation. News from Rohde & Schwarz (2003) No. 180, pp 21–27