



# The all-purpose instrument for all major digital and analog TV standards

Transmitter production, installation, and service require measuring equipment that can handle the wide variety of TV standards in place around the world. The new R&S® ETL multistandard platform (FIG 1) ideally fulfills these needs. It not only analyzes all conventional TV standards and offers spectrum analysis functions, but it is also open for future developments.

## In vogue: multistandard platforms

Not infrequently, broadcasters must set up and operate multiple transmitter networks in parallel using varying standards. In addition to the analog transmitter networks still in use, these are largely networks for digital terrestrial television, and more recently also for mobile television. The standards vary accordingly – a situation that affects not only manufacturers of TV transmitters, but also the service providers who install and maintain transmitters around the world. All users share the desire to employ as few measurement instruments as possible in their daily tasks; this means they need equipment that handles all of the necessary measurements for all standards being used. The new R&S® ETL TV analyzer with its multistandard platform concept is the perfect answer to these needs.

## Innovative device concept

The R&S® ETL designers didn't just think about combining all significant TV standards in a single device. They also wanted to create the most flexible platform possible – one that can quickly be adapted to any future developments such as new standards or enhancements of existing standards. The result is an innovative device concept that integrates both hardware- and software-based demodulators.

## Software-based demodulators

Normally, commercially available, hardware-based demodulators are used in TV analyzers. This reduces the development effort as well as the procurement costs for these devices. However, these advantages are offset by fundamental disadvantages. For example, commercial hardware demodulators typically offer only limited performance, oriented toward the terminal equipment it is designed for (set-top boxes, mobile phones). In addition, the options are limited both for implementing new types of measurements and for quickly adapting them to evolving market requirements.

To avoid these disadvantages, Rohde & Schwarz has developed software-based demodulators. One of the main considerations was to ensure that these demodulators operate in realtime in order to detect short-duration interference and to provide uninterrupted demodulation and continuous recording of measured values. The results are convincing: The new software-based demodulators meet these criteria with a performance that simply cannot be achieved by hardware-based demodulators.

The central component is a field programmable gate array (FPGA) that can be "loaded" with the demodulator to be used (FIG 2). This makes integrating new standards in the R&S® ETL as easy as switching among the various demodulators. New demodulators can be activated simply with a license key. And the R&S® ETL is extremely versatile: Besides its software-based demodulators, it also allows the use of hardware-based demodulators if they offer sufficient

◀ FIG 1  
The R&S® ETL combines TV test receiver and spectrum analyzer functionality in a single unit while providing high measurement accuracy.

► performance. The R&S®ETL is perfectly suited to handle any task both now and in the future.

### Analysis in realtime

Speed is not only an advantage when carrying out measurements, but also when analyzing TV signals. In addition to its innovative demodulators, the high-speed signal processing in the R&S®ETL also makes it possible to detect short-duration interference as well as to perform adjustments in realtime.

The speed of the R&S®ETL becomes especially apparent when displaying the constellation of digitally modulated TV signals (FIG 3), when displaying the channel impulse response for DVB-T/-H, or when measuring the frequency response, group delay, and phase in the TV channel.

### Efficiency through versatility

Versatility in a TV analyzer means not only that it can handle large numbers of TV standards, but also that it can provide all of the different measurements needed across a variety of applications.

The R&S®ETL also fits the bill here due to its extensive array of measurements and functions for analyzing TV signals at the modulation level or in the frequency spectrum. This combination of TV signal analysis and spectrum analysis in a single unit and with a common user interface allows rapid processing of measurements, even after only brief training. In most cases, the only measuring equipment needed is the R&S®ETL – an efficient all-purpose instrument, indeed.

The frequency range of the analyzer is from 500 kHz to 3 GHz. As a result, it covers not only the conventional broadcast frequencies, but also the increasingly important frequencies in the L and S bands, considerably expanding its range of applications. It is already designed to analyze the analog TV standards used worldwide, as well as the digital standards DVB-T/-H, DVB-C, and DTMB (China, GB20600-2006 standard).

The wide variety of TV-specific measurements provided by the R&S®ETL is complemented by spectrum measurements usually available only with spectrum analyzers. As a result, measurements such as shoulder distance in accordance with ETSI TR101290, channel power, and adjacent-channel power can be carried out using a single instrument. Special functions such as frequency counters as well as noise and phase noise markers round out the range of measurement functions.

FIG 2 Block diagram of the R&S®ETL TV analyzer.

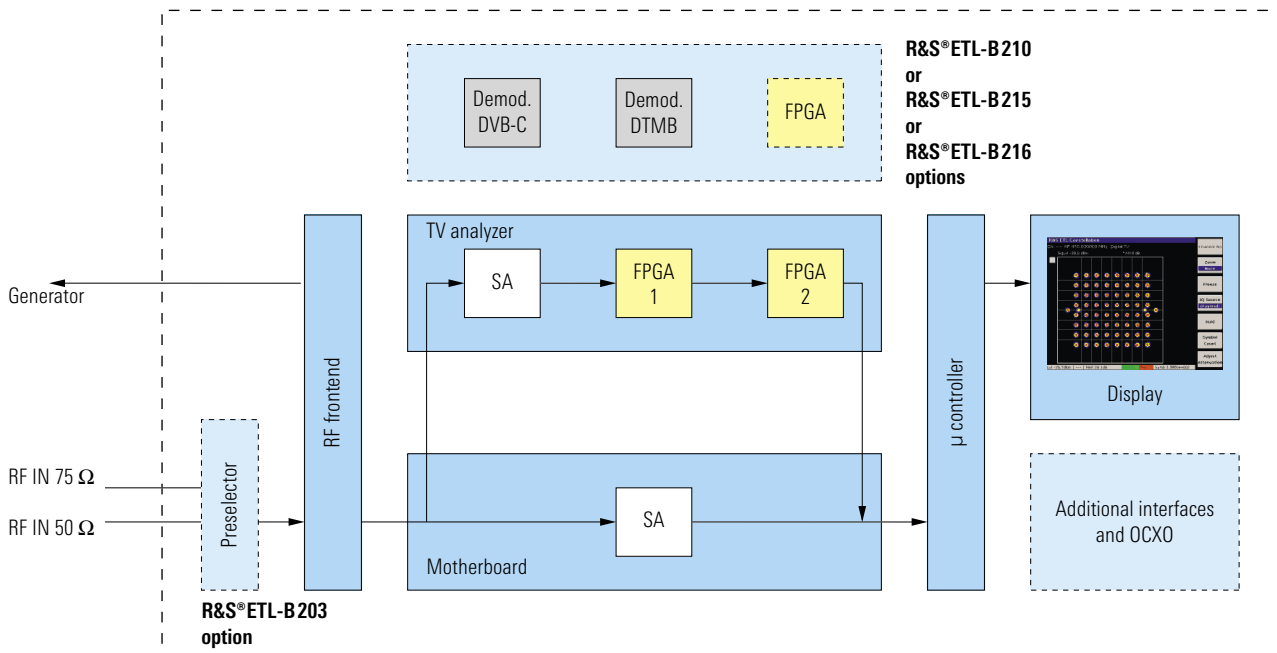

## For transmitters or cable headends

The R&S®ETL TV analyzer offers all significant measurements required for acceptance testing, maintenance, and servicing of DVB-T/-H transmitters or digital cable headends. The central screen contains the *Digital Overview*, which provides a clear display of all essential parameters (FIG 4). A pass/fail display shows at a glance whether all parameters are within tolerances. Soft-keys provide quick access to additional measurements. All quality parameters are quickly recorded step-by-step.

The R&S®ETL offers a series of measurements for analog TV, enhanced by a video scope function (FIG 5). As a result, additional measurements are available for analog TV signals that haven't already been replaced by digital standards. You can read more about transmitter measurements using the R&S®ETL starting on page 53.

## Options for just about any task

Because the R&S®ETL is primarily designed for work at different sites, a lot of emphasis was placed on low weight, robust housing, and compact dimensions. But in spite of its small size, it offers a surprising palette of options for a wide variety of tasks.

For example, it can be equipped with an internal preselector that has an additional 75 Ω RF input. This makes it possible not only to make measurements on full-capacity TV cable systems, but also to perform coverage measurements in the field. ▶

**FIG 3**  
Constellation diagram of a DVB-T/-H signal (additional C/N = 30 dB).



**FIG 4**  
All essential parameters at a glance (e.g. for DVB-T/-H). The MER value is also shown enlarged (zoom function).

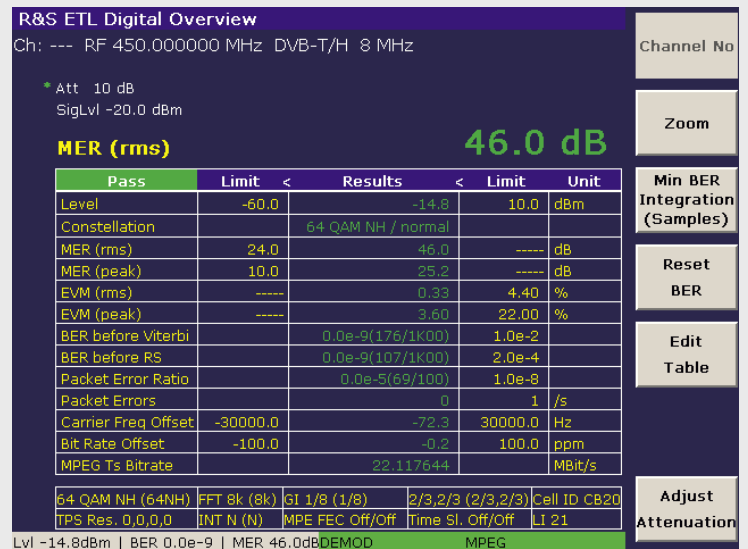

**FIG 5**  
Video scope function for analog TV with display of the SNR value.

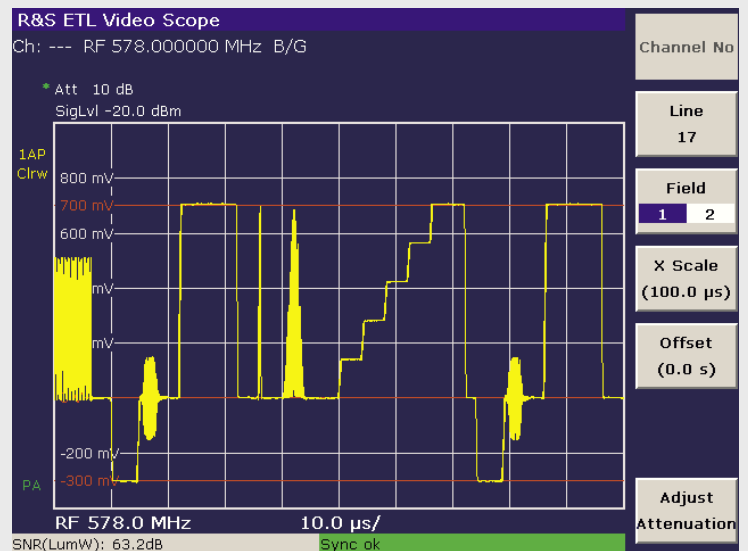



45151/77

**FIG 6** The user can simply plug new options for the R&S®ETL into the slots on the rear panel.

- ▶ The rear panel offers multiple slots for additional interfaces (FIG 6), e.g. I/Q inputs for use in research and development or in the series production of chips, as well as GPIB or DC interfaces. Users can quickly install these options themselves.

A special feature are the MPEG options for the R&S®ETL that offer an in-depth analysis of the MPEG baseband usually available only with separate MPEG-2 transport stream analyzers. These options also allow a TV picture to be displayed on the R&S®ETL screen, thus rounding out the varied analysis functions covering everything from RF and modulation through to the baseband. These options will be presented in more detail in one of the next issues.

### Summary

The R&S®ETL TV analyzer is a versatile platform, in particular with respect to TV transmitter commissioning, installation, and service, as well as coverage measurements for terrestrial television, and measurements on cable head-ends. Using only a single unit, broadcast transmitters or CATV systems can be installed easily and with high precision, and maintained cost-effectively. Due to its compact and robust design, the R&S®ETL is suitable for mobile applications, which greatly simplifies network coverage measurements.

Werner Dürport

More information, product brochure and data sheet at [www.rohde-schwarz.com](http://www.rohde-schwarz.com) (search term: ETL)

 The complex block contains a blue header with white text providing a link to more information. Below the text are two small rectangular images: the left one shows the R&S ETL TV analyzer with the text 'R&S®ETL TV Analyzer The universal multi-standard platform for the analysis of TV and mobile TV signals' and the '75th Anniversary' logo; the right one shows the 'R&S®ETL TV Analyzer Specifications' document with the '75th Anniversary' logo.

# Measurements using the R&S® ETL TV analyzer

## A wide field: measurements on digital terrestrial broadcast transmitters

Error-free functioning of broadcast transmitters must be ensured during their production, commissioning, and operation. Moreover, different countries and different customers impose different limit values on transmitters that must be met. As a general rule, therefore, testing is required for the following functions:

- ◆ **Modulation parameters:** In addition to the obligatory frequency setting, modulation standards and modes as well as baseband signals should be checked. Measurement of the modulation error ratio (MER) is an important benchmark. However, transmission errors should also be measured (BER measurement).
- ◆ **Transmitter parameters:** The essential parameters are output power and I/Q alignment.
- ◆ **Pre-correction:** The signal being transmitted must be pre-corrected in the exciter. The exciter should therefore be

specifically set for each transmitter during production. Changes to the overall system require realignment, even during operation.

- ◆ **Spurious emissions:** The transmitting system must be checked to determine if it affects other transmission channels during operation.

A possible test setup for transmitter acceptance testing is shown in FIG 7. As a complement to the R&S® ETL, the R&S® DVM 400 MPEG-2 monitoring system from Rohde & Schwarz completes the range of measuring instruments (see page 59 for news about the R&S® DVM). Besides analyzing the MPEG-2 transport stream and decoding the included programs, the system also applies a reference transport stream to the transmitter's exciter for test purposes. Power ratings of several kilowatts at the transmitter's antenna output make measurements there impossible. Therefore, a directional coupler decouples a portion of the actual power and sends it to the test receiver.

**FIG 7**  
Typical test setup for transmitter acceptance testing.

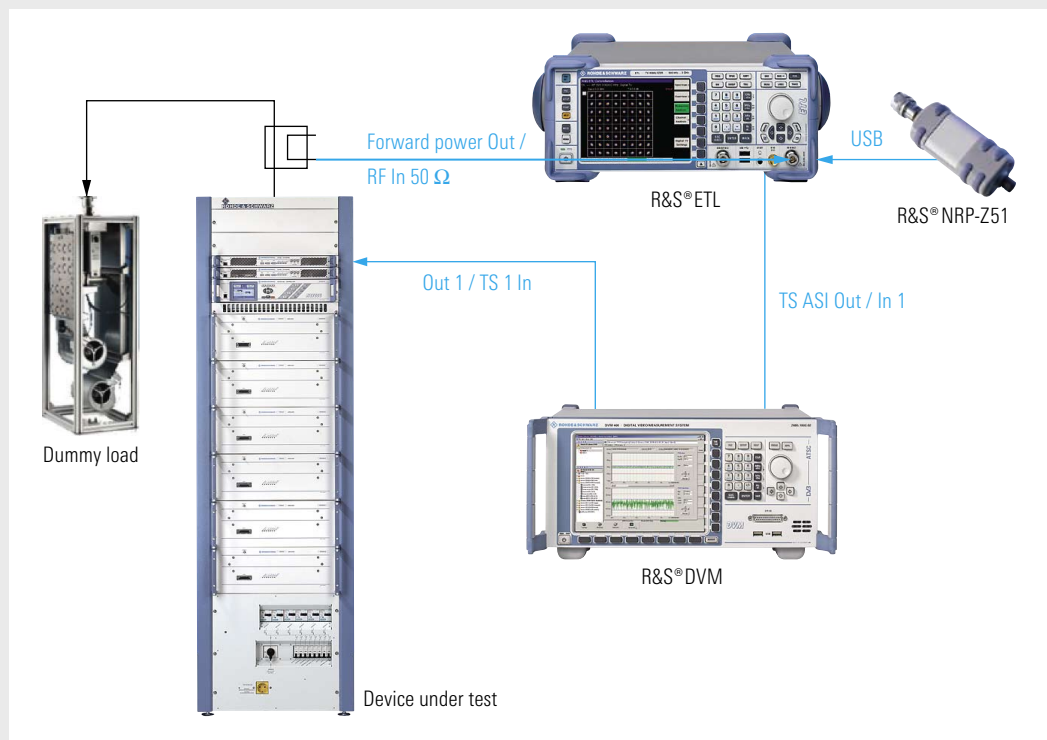

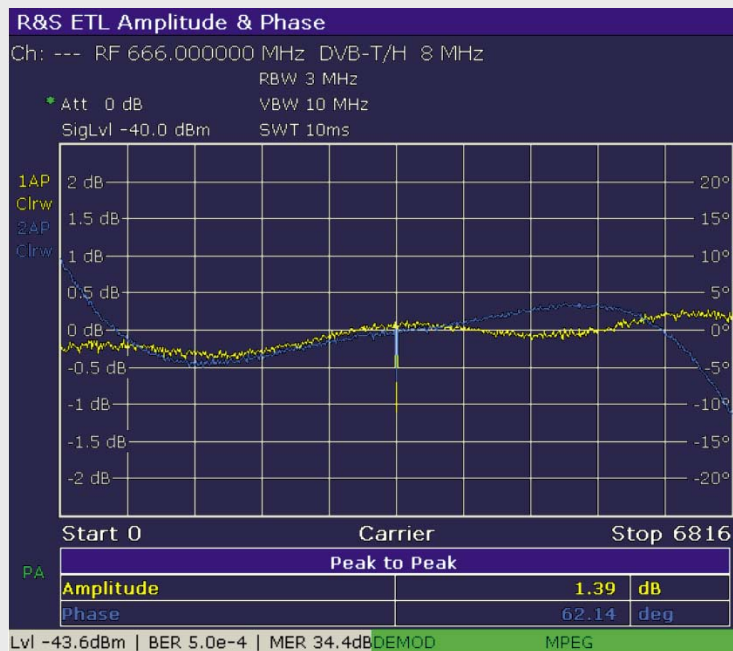
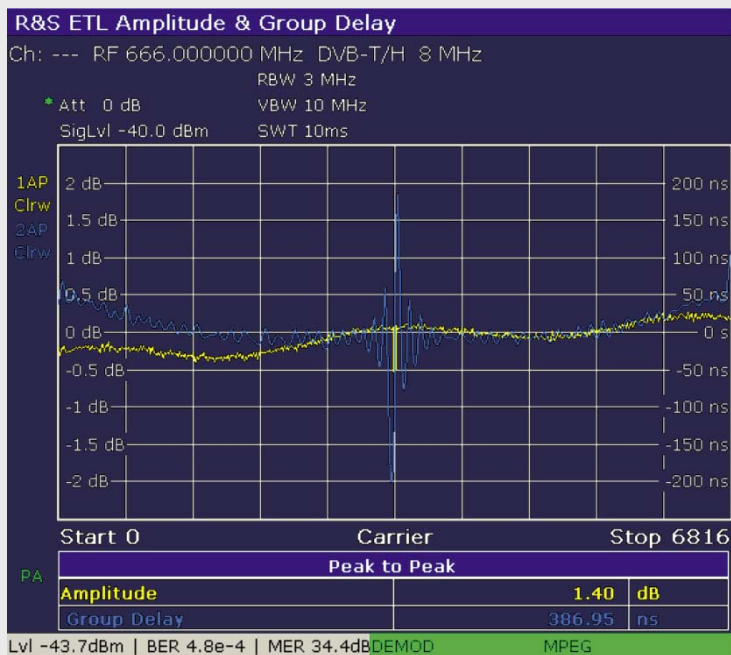

FIGS 8 and 9 Amplitude, group delay, and phase response show linear distortions within the transmission channel. The measurement after the channel filter, in particular, makes it possible to determine the quality of the linear precorrection used.

- ▶ This means that various completely different measurement functionalities, i.e. TV analyzer, spectrum analyzer, and power meter, are required. The new R&S®ETL TV analyzer from Rohde & Schwarz combines all of these functionalities in a single unit. A brief description of these functionalities and the essential measurements follows.

### TV analyzer measurement functionality

The R&S®ETL measures all modulation-specific parameters in realtime, evaluates them, and displays them graphically. By virtue of its software-based demodulators, it can support a broad range of standards. In addition to the constellation diagram (FIG 3) and the central "Overview" view (FIG 4), FIGs 8 through 11 show additional measurement functions based on the DVB-T/-H implementation.

### Power measurement

The R&S ETL® can also serve as the base unit for the power sensors of the R&S®NRP family, and thus can be used to evaluate

and display the signal power (FIG 12). The R&S®NRP-Z51 thermal power sensor is especially suited for precision measurements of the RMS power, e.g. for DVB-T/-H.

### Spectrum analysis

In addition to its TV analyzer measurement functionality, the R&S®ETL offers an array of familiar measurement functions from the Rohde & Schwarz family of spectrum analyzers. Their description would, however, exceed the scope of this article. Of paramount importance are spectrum analyzer measurements for determining out-of-band emissions.

### Summary

The R&S®ETL brings together a wide variety of measurements in a single unit, allowing users to complete their tasks quickly and effectively. Beyond the functions described here for digital television, it also supports the analysis of analog TV signals. The R&S®ETL is a well-thought-out package and the ideal instrument for checking TV transmitter quality over a diverse range of

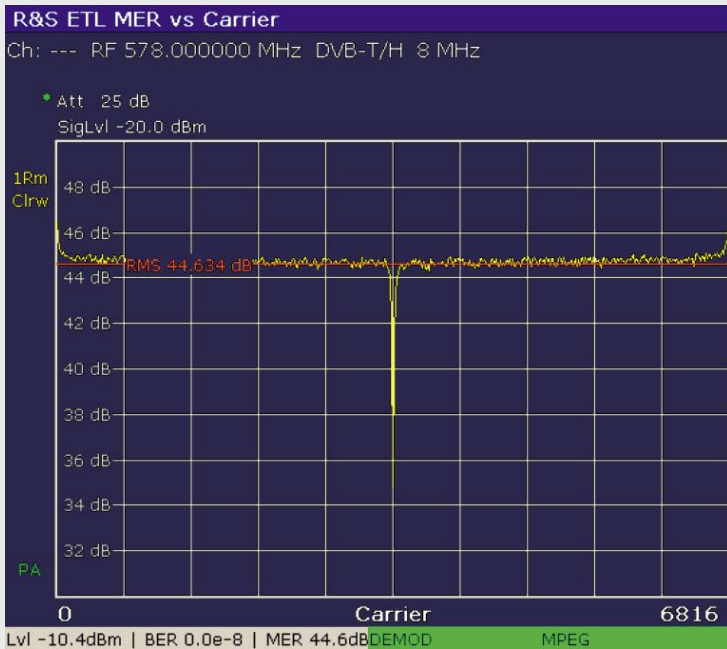

FIG 10 Besides the calculation of the RMS value for all carriers, this figure also shows the measured modulation error ratio (MER) as a function of the carrier. This makes it possible to identify problems during I/Q alignment as well as possible interference or distortion in the channel.

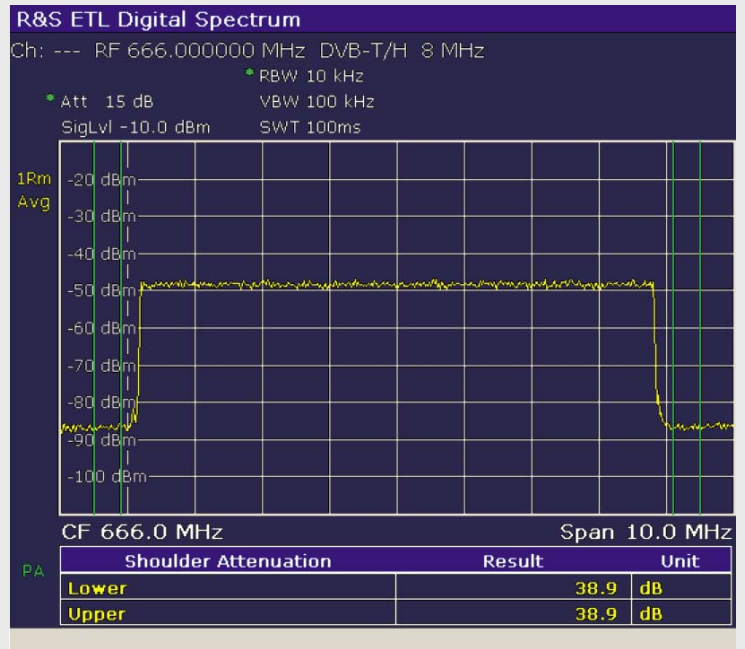

FIG 11 During the spectrum measurement, the “Shoulder Attenuation” function permits the power to be measured in the directly adjacent channels. This measurement is implemented in accordance with the ETSI TR 101290 standard.

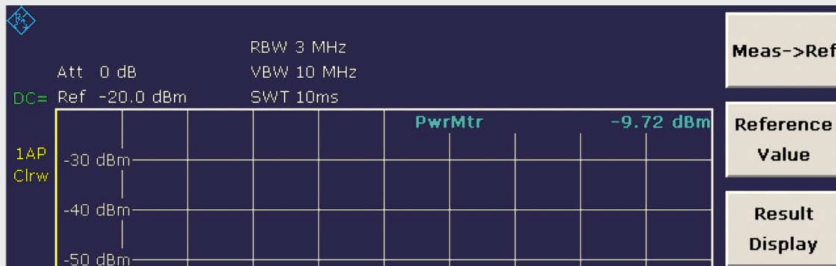

FIG 12 The R&S®ETL can also serve as the base unit for the power sensors of the R&S®NRP family.

applications. Its extensive measurement capabilities (e.g. MER >40 dB) allow early diagnosis of dangerous trends during routine checks so that countermeasures can be taken before the transmitter system fails. For more details regarding transmitter measurements, see the 38-page application note [Quality Measurements on Digital and Analog TV Transmitters Using the R&S®ETL](#), available for free download under the search term “7BM67” on the Rohde & Schwarz website.

Harald Gsödl

